

17087

STAHLS

4RSPH $\frac{1}{4}$ AR

Pat Taylor

From: Greg Merrihew <greg.m@lenco-harvesters.com>
Sent: Tuesday, May 09, 2017 2:53 PM
To: 'Brad Johnston'; NickHagerman@icloud.com; 'Pat Taylor'
Subject: FW: Cummins Visit for Stahl Build

FYI

From: Jason Cooper [mailto:jason.cooper@cummins.com]
Sent: Tuesday, May 9, 2017 2:46 PM
To: Greg Merrihew <greg.m@lenco-harvesters.com>
Cc: Jason Randall <jason.randall@cummins.com>
Subject: Cummins Visit for Stahl Build

Greg,

The Stahl build is progressing quite nicely with most of the major challenges worked out on our end.

I know you and your people are super busy, but do you see any value in sending a guy, or two down to us for a morning to look at the build first-hand before we disassemble and send to you? We'll of course take plenty of pictures to share, but it could be useful if they see it with their own eyes first. Let me know. Thanks

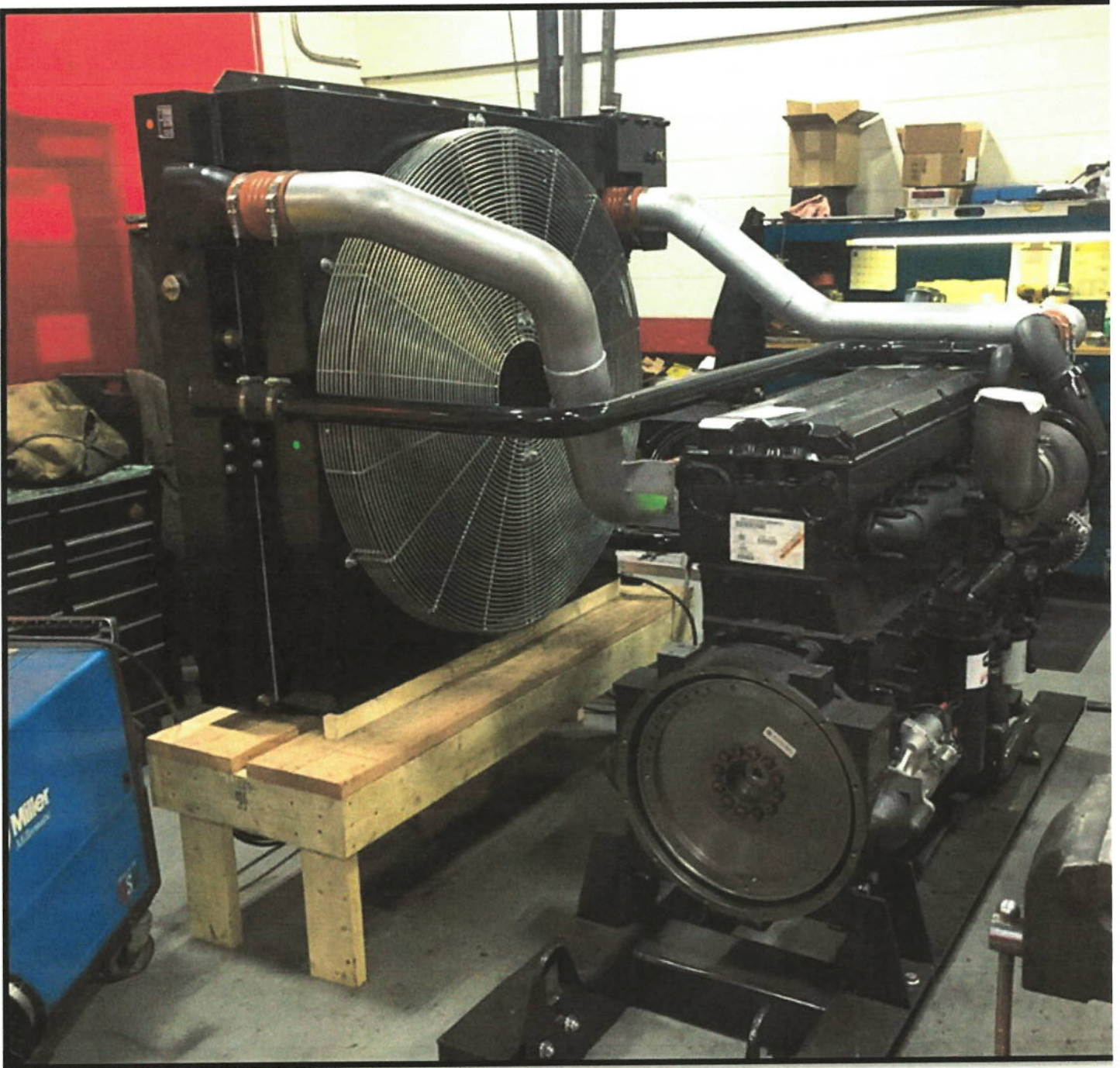

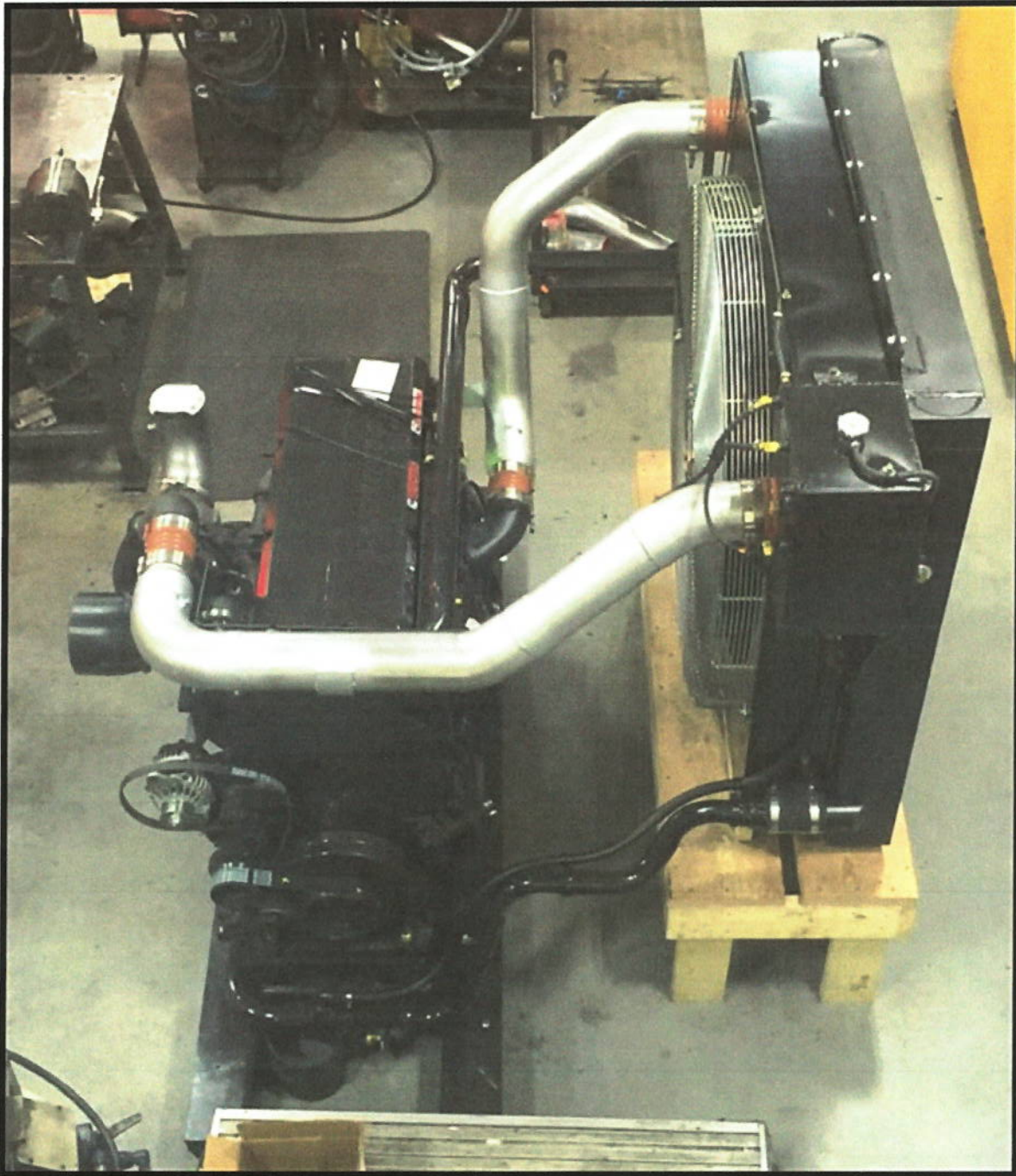

Regards,

Jason Cooper
OEM Account Manager
Cummins Sales and Service
3715 Clay Ave. S.W.
Grand Rapids, MI 49548
Office: 616-855-5864
Cell: 812-343-5729
jason.cooper@cummins.com

PACKING SLIP

Advanced Farm Equipment LLC

5773 Crystal Road
Vestaburg MI 48891
(989) 268-5711

Packing Slip Number 049678

Packing Slip Date 05/05/17

Page 1

SOLD Stahl Hutterian Brethren
TO 1485 N. Hoffman Rd.
Ritzville, WA 99169

SHIP Stahl Hutterian Brethren
TO 1485 N. Hoffman Rd.
Ritzville, WA 99169

P.O. Number	Martin // Pat	Terms	Net 30
Ship Via	UPS - Ground	Salesperson	Greg Merrihew
Project Code	N/A	Required	05/05/2017
Ship Number			

ITEM	ORDERED	SHIPPED	BO	DESCRIPTION	PRICE	AMOUNT	TAX
	1.000	1.000	.000	Cab Arm Rest Assy. With Wire Harness To Be Returned		n/a	

PRIMARY 75 CC MEGOO 300 RPM

SECONDARY 150 RPM

DEVINER

AFF TABLE

CHOPPER

CROSS

CROSS DIST

LEFT SIDE

TRASH PAN

VINE BELT

DIST.

TRASH CONV.^S

FRONT CROSS

BOOM

STEERING SEPERATE FROM CYL CIRCUIT

CYL. FUNCTIONS

PACKER WHEEL W/ ACCUMULATOR / PRESS LIMIT

DIGGER BED L/R

COULTER L/R

LIFT IN SHAKER L/R

BOOM - SWING

- LIFT

- OUTER

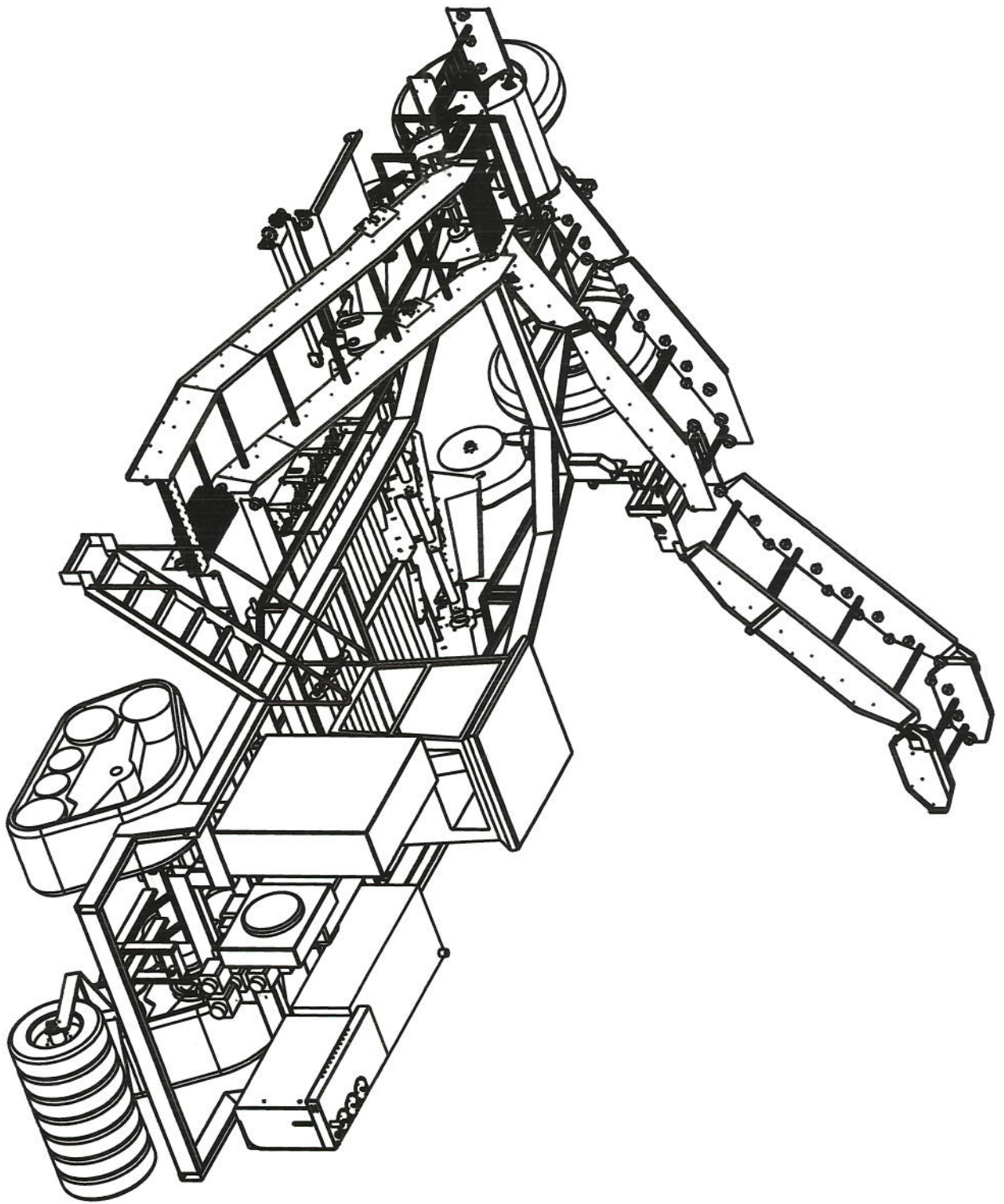

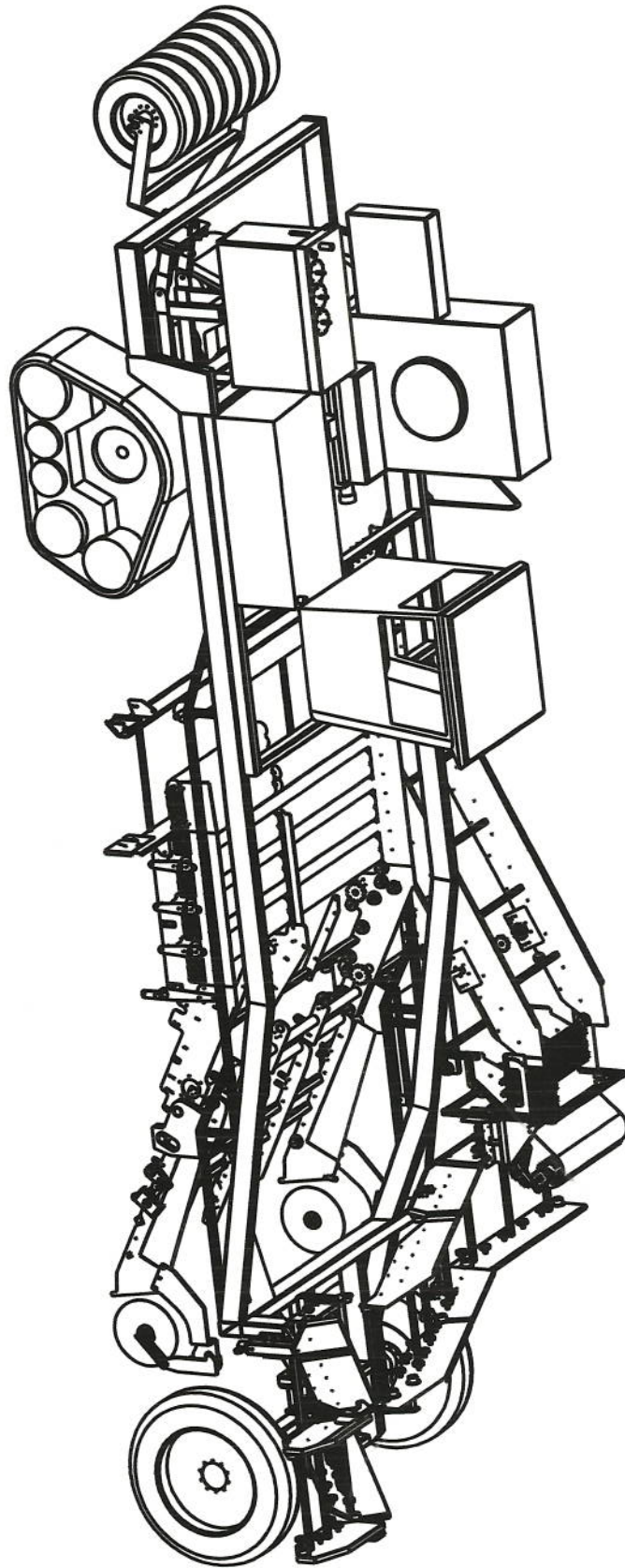

GROUND DRIVE: 3 SPEED

FRONT - BBL / SAI

REAR - ESKRIDGE w/ PARKER

ATI TRACKS

- LINE SIZE TO FRONT G.D. 1 1/4"

TRACTION CONTROL VIA FRONT & REAR MANIFOLD

GEAR BOX CONFIGURATION

CYLINDER SIZES

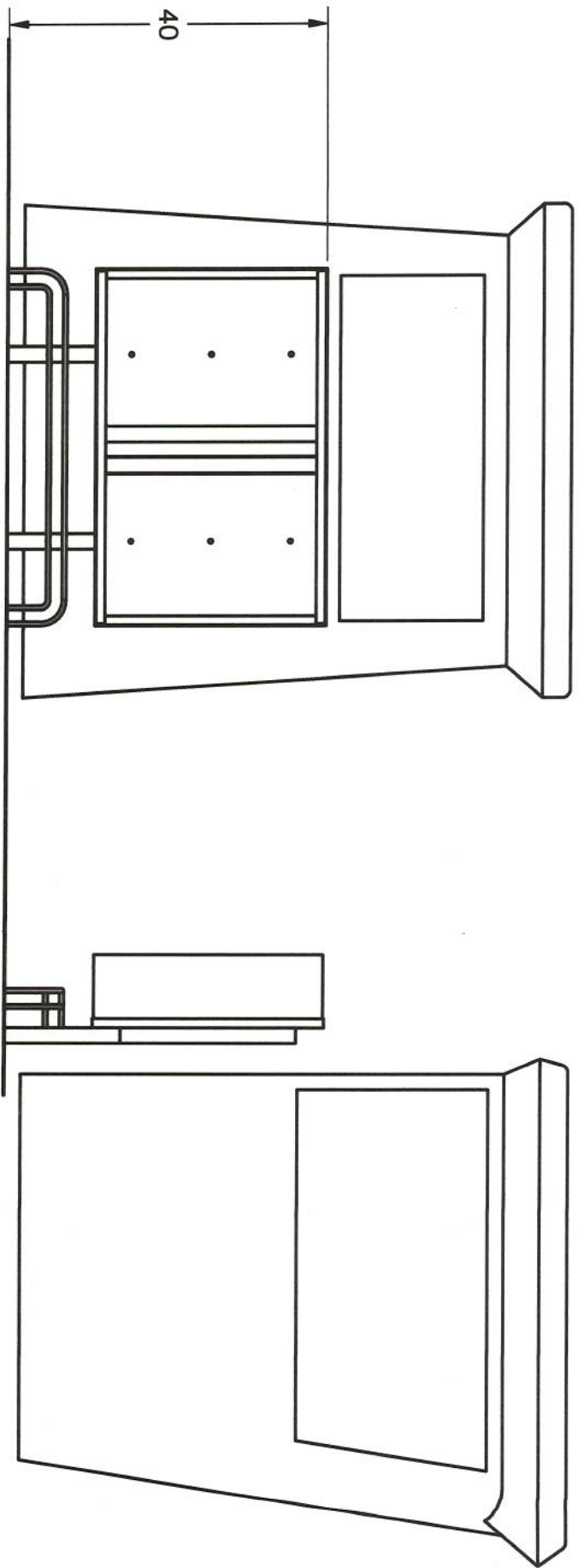

PROJECT

Digger_Lenco

TITLE

Main Box

APPROVED		SIZE	CODE	DWG NO	REV
CHECKED		A			
DRAWN	Martin Stahl	7/17/17	SCALE 1:16	WEIGHT	SHEET 1/3

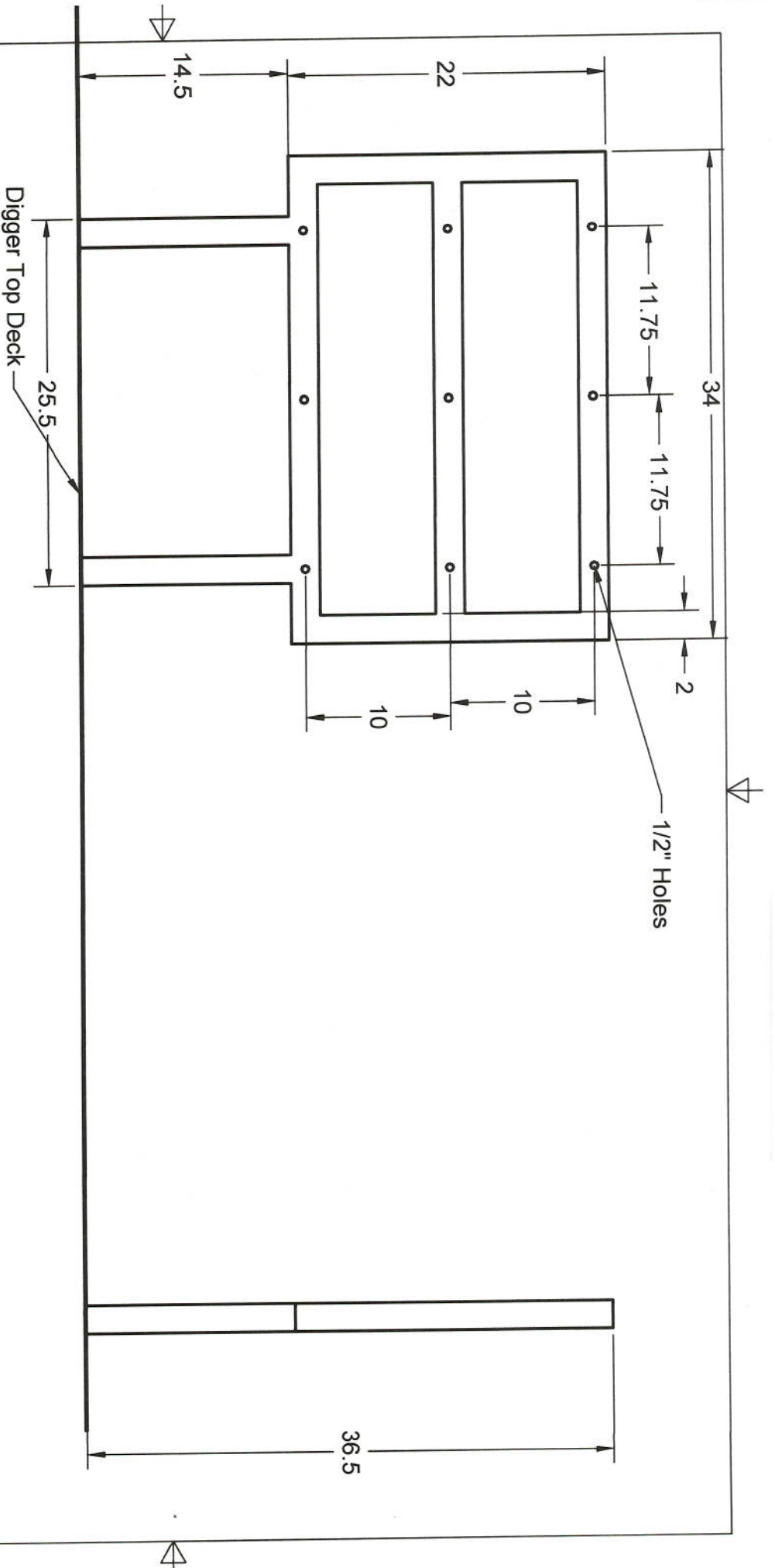

PROJECT

Digger_Lenco

TITLE

Main Box

APPROVED	SIZE	CODE	DWG NO	REV
CHECKED	A			
DRAWN	Martin Stahl	7/17/17	SCALE 1:10	WEIGHT
				SHEET 2/3

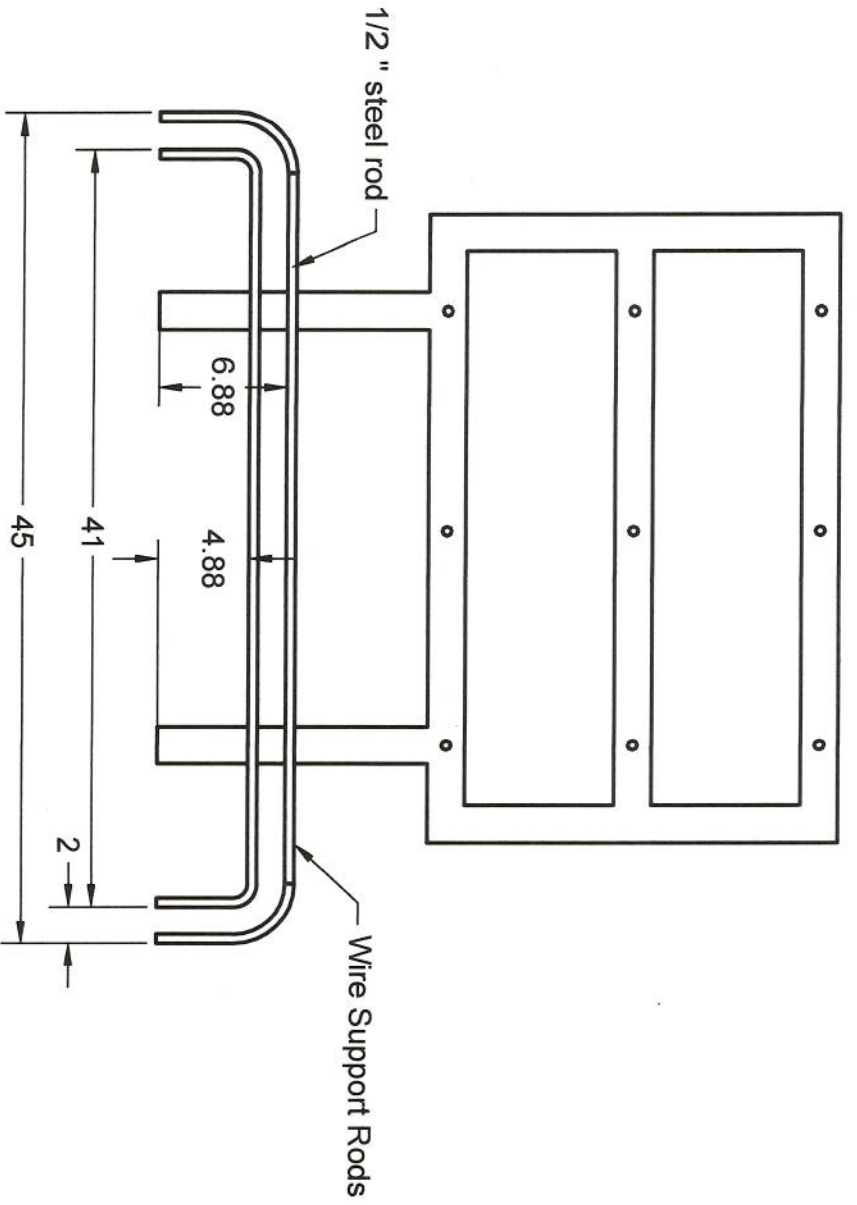

PROJECT
Digger_Lenco
 TITLE
Main Box

APPROVED		SIZE	CODE	DWG NO	REV
CHECKED		A			
DRAWN	Martin Stahl	7/17/17	SCALE 1:10	WEIGHT	SHEET 3/3



PACKING LIST

Branch: GRANDVILLE
3560 Busch Drive
Grandville, MI 49418
USA

Invoice Number	
30922421	
Invoice Date	Page
7/31/2017 09:54:15	1 of 1
Your PO Number	
056676	

Ship To:

ADVANCED FARM EQUIPMENT
5773 CRYSTAL ROAD
VESTABURG, MI 48891
US

Bill To:

ADVANCED FARM EQUIPMENT
5773 CRYSTAL ROAD
VESTABURG, MI 48891
US
877-287-5711

Ordered By: Kim Bollinger
Customer ID: 104293

ORDER NUMBER	Terms Description	Net Due Date	Disc Due Date	Discount Amount
1688622	NET 30	8/30/2017	8/30/2017	

Order Date	Pick Ticket No	Primary Salesrep Name	Taker
3/20/2017 15:42:06	20939918	Scott. Drew	BBUCHOLTZ

Quantities			Item ID
Ordered	Shipped	Remaining	Item Description
1.0000	1.0000	0.0000	421AK00650B

Carrier: DELIVER

Tracking #:

1.0000

1.0000

0.0000

421AK00650B

4.88 CID(80CC)420 CODE B

ADU080L05AB10A18150000100100CD0B

Customer Part No: 2010-00210

Contract Name: 104293

Line Number: 300

Total Lines: 1
Total Pieces: 1
Total Weight: 0

LG

① DTS - 31100
Daman E-28000REU1
C1109417

Picked up
by greg

ALL SALES ARE EXPRESSLY SUBJECT TO DTS FLUIDPOWER LLC STANDARD TERMS AND CONDITIONS OF SALE, COPIES OF WHICH ARE FOUND ON OUR WEBSITE [HTTP://WWW.DTSFLUIDPOWER.COM/TERMS/TERMSOFSALE.PHP](http://www.dtsfluidpower.com/terms/terms_of_sale.php). ADDITIONAL COPIES OF THE STANDARD TERMS AND CONDITIONS OF SALE ARE AVAILABLE ON REQUEST. ANY DIFFERENT OR ADDITIONAL TERMS AND CONDITIONS SET FORTH IN BUYER'S PURCHASE ORDER OR SIMILAR COMMUNICATIONS ARE OBJECTED TO AND SHALL NOT BE BINDING ON DTS FLUIDPOWER LLC UNLESS AGREED TO IN WRITING BY A DTS FLUIDPOWER LLC CORPORATE OFFICER.

Packing List Number: 30922421



PACKING LIST

Branch: GRANDVILLE
 3560 Busch Drive
 Grandville, MI 49418
 USA

Invoice Number	
30865222	
	
Invoice Date	Page
4/6/2017 14:47:34	1 of 1
Your PO Number	
056676	

Ship To:
ADVANCED FARM EQUIPMENT
5773 CRYSTAL ROAD
VESTABURG, MI 48891
US

Bill To:
 ADVANCED FARM EQUIPMENT
 5773 CRYSTAL ROAD
 VESTABURG, MI 48891
 US
 877-287-5711

Ordered By: Kim Bollinger
 Customer ID: 104293

ORDER NUMBER	Terms Description	Net Due Date	Disc Due Date	Discount Amount
1688622	NET 30	5/6/2017	5/6/2017	

Order Date	Pick Ticket No	Primary Salesrep Name	Taker
3/20/2017 15:42:06	20879821	Scott. Drew	BBUCHOLTZ

Quantities			Item ID	Item Description
Ordered	Shipped	Remaining		

Carrier: DELIVER

Tracking #:

4.0000

BB
 1.0000

0.0000

RTF-N500L10/B/22
 INSERT FILTER ASSEMBLY W/ 10 MICRON
 PAPE
 INSERT FILTER ASSEMBLY W/ 10 MICRON
 PAPER ELEMENT

Customer Part No: 2015-067

Contract Name: 104293

Line Number: 114

Total Lines: 1
 Total Pieces: 1
 Total Weight: 0

17087

ALL SALES ARE EXPRESSLY SUBJECT TO DTS FLUIDPOWER LLC STANDARD TERMS AND CONDITIONS OF SALE, COPIES OF WHICH ARE FOUND ON OUR WEBSITE [HTTP://WWW.DTSFLUIDPOWER.COM/TERMS/TERMSOFSALE.PHP](http://WWW.DTSFLUIDPOWER.COM/TERMS/TERMSOFSALE.PHP). ADDITIONAL COPIES OF THE STANDARD TERMS AND CONDITIONS OF SALE ARE AVAILABLE ON REQUEST. ANY DIFFERENT OR ADDITIONAL TERMS AND CONDITIONS SET FORTH IN BUYER'S PURCHASE ORDER OR SIMILAR COMMUNICATIONS ARE OBJECTED TO AND SHALL NOT BE BINDING ON DTS FLUIDPOWER LLC UNLESS AGREED TO IN WRITING BY A DTS FLUIDPOWER LLC CORPORATE OFFICER.

Packing List Number: 30865222



PACKING LIST

Branch: GRANDVILLE
 3560 Busch Drive
 Grandville, MI 49418
 USA

Invoice Number	
30865232	
Invoice Date	Page
4/6/2017 14:50:59	1 of 1
Your PO Number	
056676	

Ship To:

ADVANCED FARM EQUIPMENT
5773 CRYSTAL ROAD
VESTABURG, MI 48891
US

Bill To:

ADVANCED FARM EQUIPMENT
 5773 CRYSTAL ROAD
 VESTABURG, MI 48891
 US
 877-287-5711

Ordered By: Kim Bollinger
 Customer ID: 104293

ORDER NUMBER	Terms Description	Net Due Date	Disc Due Date	Discount Amount
1688622	NET 30	5/6/2017	5/6/2017	
Order Date	Pick Ticket No	Primary Salesrep Name		Taker
3/20/2017 15:42:06	20878145	Scott. Drew		BBUCHOLTZ
Quantities			Item ID	Item Description
Ordered	Shipped	Remaining		
1.0000	1.0000	0.0000	KM30.73R0-A8K9-LOF/OF-N-CSC-SAE6	KAPPA 30 SERIES PUMP
Carrier: DAYTON FREIGHT		Tracking #:		

Total Lines: 1
 Total Pieces: 1
 Total Weight: 0

17087

ALL SALES ARE EXPRESSLY SUBJECT TO DTS FLUIDPOWER LLC STANDARD TERMS AND CONDITIONS OF SALE, COPIES OF WHICH ARE FOUND ON OUR WEBSITE [HTTP://WWW.DTSFLUIDPOWER.COM/TERMS/TERMSOFSALE.PHP](http://www.dtsfluidpower.com/terms/terms_of_sale.php). ADDITIONAL COPIES OF THE STANDARD TERMS AND CONDITIONS OF SALE ARE AVAILABLE ON REQUEST. ANY DIFFERENT OR ADDITIONAL TERMS AND CONDITIONS SET FORTH IN BUYER'S PURCHASE ORDER OR SIMILAR COMMUNICATIONS ARE OBJECTED TO AND SHALL NOT BE BINDING ON DTS FLUIDPOWER LLC UNLESS AGREED TO IN WRITING BY A DTS FLUIDPOWER LLC CORPORATE OFFICER.

Packing List Number: 30865232



PACKING LIST

Branch: GRANDVILLE
 3560 Busch Drive
 Grandville, MI 49418
 USA

Invoice Number	
30857661	
	
Invoice Date	Page
3/23/2017 13:15:09	1 of 1
Your PO Number	
056676	

Ship To:

ADVANCED FARM EQUIPMENT
5773 CRYSTAL ROAD
VESTABURG, MI 48891
US

Bill To:

17087
 ADVANCED FARM EQUIPMENT
 5773 CRYSTAL ROAD
 VESTABURG, MI 48891
 US
 877-287-5711

Ordered By: Kim Bollinger

Customer ID: 104293

ORDER NUMBER	Terms Description	Net Due Date	Disc Due Date	Discount Amount
1688622	NET 30	4/22/2017	4/22/2017	

Order Date	Pick Ticket No	Primary Salesrep Name	Taker
3/20/2017 15:42:06	20872896	Scott. Drew	BBUCHOLTZ

Quantities			Item ID	Item Description
Ordered	Shipped	Remaining		
4.0000	4.0000	0.0000	SF-130-03-0	FILTER HEAD [6] 1IN SAE PORTS & 3PSI BY-PASS
4.0000	4.0000	0.0000	SE-100	100 MESH SPIN O [6] 100 MESH SPIN ON FILTER ELEMEN

Carrier: DELIVER

Tracking #:

4.0000

4.0000

0.0000

SF-130-03-0
 FILTER HEAD [6]
 1IN SAE PORTS & 3PSI BY-PASS

Customer Part No: 2016-069

4.0000

4.0000

0.0000

SE-100
 100 MESH SPIN O [6]
 100 MESH SPIN ON FILTER ELEMEN

Customer Part No: 2022-0463

Total Lines: 2
 Total Pieces: 8
 Total Weight: 0

RS

ALL SALES ARE EXPRESSLY SUBJECT TO DTS FLUIDPOWER LLC STANDARD TERMS AND CONDITIONS OF SALE. COPIES OF WHICH ARE FOUND ON OUR WEBSITE [HTTP://WWW.DTSFLUIDPOWER.COM/TERMS/TERMS_OF_SALE.PHP](http://www.dtsfluidpower.com/terms/terms_of_sale.php). ADDITIONAL COPIES OF THE STANDARD TERMS AND CONDITIONS OF SALE ARE AVAILABLE ON REQUEST. ANY DIFFERENT OR ADDITIONAL TERMS AND CONDITIONS SET FORTH IN BUYER'S PURCHASE ORDER OR SIMILAR COMMUNICATIONS ARE OBJECTED TO AND SHALL NOT BE BINDING ON DTS FLUIDPOWER LLC UNLESS AGREED TO IN WRITING BY A DTS FLUIDPOWER LLC CORPORATE OFFICER.

Packing List Number: 30857661



Branch: GRANDVILLE
 3560 Busch Drive
 Grandville, MI 49418
 USA

PACKING LIST

Invoice Number	
30857639	
	
Invoice Date	Page
3/23/2017 13:10:06	1 of 1
Your PO Number	
056676	

Ship To:

ADVANCED FARM EQUIPMENT
5773 CRYSTAL ROAD
VESTABURG, MI 48891
US

Bill To: 17087

ADVANCED FARM EQUIPMENT
 5773 CRYSTAL ROAD
 VESTABURG, MI 48891
 US
 877-287-5711

Ordered By: Kim Bollinger
 Customer ID: 104293

ORDER NUMBER	Terms Description	Net Due Date	Disc Due Date	Discount Amount
1688622	NET 30	4/22/2017	4/22/2017	
Order Date	Pick Ticket No	Primary Salesrep Name		Taker
3/20/2017 15:42:06	20873226	Scott. Drew		BBUCHOLTZ
Quantities			Item ID	Item Description
Ordered	Shipped	Remaining		
4.0000	3.0000	1.0000	RTF-N500L10/B/22	INSERT FILTER ASSEMBLY W/ 10 MICRON PAPER ELEMENT
Carrier: DELIVER		Tracking #:		
		Customer Part No: 2015-067		
		Contract Name: 104293		Line Number: 114

Total Lines: 1
 Total Pieces: 3
 Total Weight: 0

ALL SALES ARE EXPRESSLY SUBJECT TO DTS FLUIDPOWER LLC STANDARD TERMS AND CONDITIONS OF SALE. COPIES OF WHICH ARE FOUND ON OUR WEBSITE [HTTP://WWW.DTSFLUIDPOWER.COM/TERMS/TERMSOFSALE.PHP](http://www.dtsfluidpower.com/terms/termsofsale.php). ADDITIONAL COPIES OF THE STANDARD TERMS AND CONDITIONS OF SALE ARE AVAILABLE ON REQUEST. ANY DIFFERENT OR ADDITIONAL TERMS AND CONDITIONS SET FORTH IN BUYER'S PURCHASE ORDER OR SIMILAR COMMUNICATIONS ARE OBJECTED TO AND SHALL NOT BE BINDING ON DTS FLUIDPOWER LLC UNLESS AGREED TO IN WRITING BY A DTS FLUIDPOWER LLC CORPORATE OFFICER.

Packing List Number: 30857639



PACKING LIST

Branch: GRANDVILLE
 3560 Busch Drive
 Grandville, MI 49418
 USA

Invoice Number	
30857653	
	
Invoice Date	Page
3/23/2017 13:13:02	1 of 1
Your PO Number	
056676	

Ship To:

ADVANCED FARM EQUIPMENT
5773 CRYSTAL ROAD
VESTABURG, MI 48891
US

Bill To:

17087

ADVANCED FARM EQUIPMENT
 5773 CRYSTAL ROAD
 VESTABURG, MI 48891
 US
 877-287-5711

Ordered By: Kim Bollinger
 Customer ID: 104293

ORDER NUMBER	Terms Description	Net Due Date	Disc Due Date	Discount Amount
1688622	NET 30	4/22/2017	4/22/2017	
Order Date	Pick Ticket No	Primary Salesrep Name		Taker
3/20/2017 15:42:06	20872475	Scott. Drew		BBUCHOLTZ
Quantities			Item ID	Item Description
Ordered	Shipped	Remaining		
1.0000	1.0000	0.0000	DTS-5419-F	L800118 SPECIAL 815-14S OHLA MODEL 800, MODIFIED
Carrier: DELIVER		Tracking #:		
2022-0642				

Total Lines: 1
 Total Pieces: 1
 Total Weight: 0

RS

ALL SALES ARE EXPRESSLY SUBJECT TO DTS FLUIDPOWER LLC STANDARD TERMS AND CONDITIONS OF SALE. COPIES OF WHICH ARE FOUND ON OUR WEBSITE [HTTP://WWW.DTSFLUIDPOWER.COM/TERMS/TERMSOFSALE.PHP](http://www.dtsfluidpower.com/terms/termsofsale.php). ADDITIONAL COPIES OF THE STANDARD TERMS AND CONDITIONS OF SALE ARE AVAILABLE ON REQUEST. ANY DIFFERENT OR ADDITIONAL TERMS AND CONDITIONS SET FORTH IN BUYER'S PURCHASE ORDER OR SIMILAR COMMUNICATIONS ARE OBJECTED TO AND SHALL NOT BE BINDING ON DTS FLUIDPOWER LLC UNLESS AGREED TO IN WRITING BY A DTS FLUIDPOWER LLC CORPORATE OFFICER.

Packing List Number: 30857653



PACKING LIST

Branch: GRANDVILLE
3560 Busch Drive
Grandville, MI 49418
USA

Invoice Number	
30868691	
	
Invoice Date	Page
4/13/2017 13:33:59	1 of 1
Your PO Number	
056676	

Ship To:

ADVANCED FARM EQUIPMENT
5773 CRYSTAL ROAD
VESTABURG, MI 48891
US

Bill To:

17087
ADVANCED FARM EQUIPMENT
5773 CRYSTAL ROAD
VESTABURG, MI 48891
US
877-287-5711

Ordered By: Kim Bollinger
Customer ID: 104293

ORDER NUMBER	Terms Description	Net Due Date	Disc Due Date	Discount Amount
1688622	NET 30	5/13/2017	5/13/2017	

Order Date	Pick Ticket No	Primary Salesrep Name	Taker
3/20/2017 15:42:06	20883506	Scott. Drew	BBUCHOLTZ

Quantities			Item ID
Ordered	Shipped	Remaining	Item Description
1.0000	1.0000	0.0000	HC180-0120-BP60

Carrier: DAYTON FREIGHT

Tracking #:

1.0000 1.0000 0.0000 AKG 180 COOLER
WITH BYPASS AND 11.5 GPM MOTOR

Customer Part No: 2020-1800

Contract Name: 104293

Line Number: 108

Total Lines: 1
Total Pieces: 1
Total Weight: 0

RS

ALL SALES ARE EXPRESSLY SUBJECT TO DTS FLUIDPOWER LLC STANDARD TERMS AND CONDITIONS OF SALE, COPIES OF WHICH ARE FOUND ON OUR WEBSITE [HTTP://WWW.DTSFLUIDPOWER.COM/TERMS/TERMSOFSALE.PHP](http://www.dtsfluidpower.com/terms/termsofsale.php). ADDITIONAL COPIES OF THE STANDARD TERMS AND CONDITIONS OF SALE ARE AVAILABLE ON REQUEST. ANY DIFFERENT OR ADDITIONAL TERMS AND CONDITIONS SET FORTH IN BUYER'S PURCHASE ORDER OR SIMILAR COMMUNICATIONS ARE OBJECTED TO AND SHALL NOT BE BINDING ON DTS

Packing List Number: 30868691



Branch: GRANDVILLE
 3560 Busch Drive
 Grandville, MI 49418
 USA

PACKING LIST

Invoice Number	
30868698	
	
Invoice Date	Page
4/13/2017 13:39:30	1 of 1
Your PO Number	
056676	

Ship To:

ADVANCED FARM EQUIPMENT
5773 CRYSTAL ROAD
VESTABURG, MI 48891
US

Bill To:

17087
 ADVANCED FARM EQUIPMENT
 5773 CRYSTAL ROAD
 VESTABURG, MI 48891
 US
 877-287-5711

Ordered By: Kim Bollinger
 Customer ID: 104293

ORDER NUMBER	Terms Description	Net Due Date	Disc Due Date	Discount Amount
1688622	NET 30	5/13/2017	5/13/2017	
Order Date	Pick Ticket No	Primary Salesrep Name		Taker
3/20/2017 15:42:06	20883438	Scott. Drew		BBUCHOLTZ
Quantities			Item ID	Item Description
Ordered	Shipped	Remaining		

Carrier: DAYTON FREIGHT

Tracking #:

1.0000

1.0000

0.0000

212-1017-002

45.11 CID CLOSD

ABU55A660CA010000DAAC3A0AA10B

Customer Part No: 2011-00023

Contract Name: 104293

Line Number: 37

Total Lines: 1
 Total Pieces: 1
 Total Weight: 0

RS

ALL SALES ARE EXPRESSLY SUBJECT TO DTS FLUIDPOWER LLC STANDARD TERMS AND CONDITIONS OF SALE. COPIES OF WHICH ARE FOUND ON OUR WEBSITE [HTTP://WWW.DTSFLUIDPOWER.COM/TERMS/TERMSOFSALE.PHP](http://www.dtsfluidpower.com/terms/termsofsale.php). ADDITIONAL COPIES OF THE STANDARD TERMS AND CONDITIONS OF SALE ARE AVAILABLE ON REQUEST. ANY DIFFERENT OR ADDITIONAL TERMS AND CONDITIONS SET FORTH IN BUYER'S PURCHASE ORDER OR SIMILAR COMMUNICATIONS ARE OBJECTED TO AND SHALL NOT BE BINDING ON DTS

Packing List Number: 30868698



PACKING LIST

Branch: GRANDVILLE
 3560 Busch Drive
 Grandville, MI 49418
 USA

Invoice Number

30875342



Invoice Date

Page

4/27/2017 10:39:53

1 of 1

Your PO Number

056676

Ship To:

**ADVANCED FARM EQUIPMENT
 5773 CRYSTAL ROAD
 VESTABURG, MI 48891
 US**

Bill To:

ADVANCED FARM EQUIPMENT
 5773 CRYSTAL ROAD
 VESTABURG, MI 48891
 US
 877-287-5711

Ordered By: Kim Bollinger

Customer ID: 104293

ORDER NUMBER		Terms Description	Net Due Date	Disc Due Date	Discount Amount
1688622		NET 30	5/27/2017	5/27/2017	
Order Date	Pick Ticket No	Primary Salesrep Name		Taker	
3/20/2017 15:42:06	20891310	Scott. Drew		BBUCHOLTZ	
Quantities			Item ID	Item Description	
Ordered	Shipped	Remaining			

Carrier: DELIVER

Tracking #:

1.0000

1.0000

0.0000

00376760

AB10.0010-02500

PLM10.10-B0-36R8-LOC/OC-N-L

Customer Part No: 2011-04003

Contract Name: 104293

Line Number: 182

Total Lines: 1
 Total Pieces: 1
 Total Weight: 0

17087 GM

LG

ALL SALES ARE EXPRESSLY SUBJECT TO DTS FLUIDPOWER LLC STANDARD TERMS AND CONDITIONS OF SALE. COPIES OF WHICH ARE FOUND ON OUR WEBSITE [HTTP://WWW.DTSFLUIDPOWER.COM/TERMS/TERMSOFSALE.PHP](http://www.dtsfluidpower.com/terms/terms_of_sale.php). ADDITIONAL COPIES OF THE STANDARD TERMS AND CONDITIONS OF SALE ARE AVAILABLE ON REQUEST. ANY DIFFERENT OR ADDITIONAL TERMS AND CONDITIONS SET FORTH IN BUYER'S PURCHASE ORDER OR SIMILAR COMMUNICATIONS ARE OBJECTED TO AND SHALL NOT BE BINDING ON DTS FLUIDPOWER LLC UNLESS AGREED TO IN WRITING BY A DTS FLUIDPOWER LLC CORPORATE OFFICER.

Packing List Number: 30875342



PACKING LIST

Branch: GRANDVILLE
3560 Busch Drive
Grandville, MI 49418
USA

Invoice Number	
30875348	
	
Invoice Date	Page
4/27/2017 10:41:56	1 of 1
Your PO Number	
056676	

Ship To:

ADVANCED FARM EQUIPMENT
5773 CRYSTAL ROAD
VESTABURG, MI 48891
US

Bill To:

ADVANCED FARM EQUIPMENT
5773 CRYSTAL ROAD
VESTABURG, MI 48891
US
877-287-5711

Ordered By: Kim Bollinger
Customer ID: 104293

ORDER NUMBER		Terms Description	Net Due Date	Disc Due Date	Discount Amount
1688622		NET 30	5/27/2017	5/27/2017	
Order Date	Pick Ticket No	Primary Salesrep Name		Taker	
3/20/2017 15:42:06	20890208	Scott. Drew		BBUCHOLTZ	
Quantities			Item ID	Item Description	
Ordered	Shipped	Remaining			
7.0000	7.0000	0.0000	DTS-30073	HF760-40.227-AS-FG006-LC-B60-OG-B-XA-U	
Carrier: DELIVER			Tracking #:		

Total Lines: 1
Total Pieces: 7
Total Weight: 0

RS

#HP04193
2022-0325

17087 GM

ALL SALES ARE EXPRESSLY SUBJECT TO DTS FLUIDPOWER LLC STANDARD TERMS AND CONDITIONS OF SALE. COPIES OF WHICH ARE FOUND ON OUR WEBSITE [HTTP://WWW.DTSFLUIDPOWER.COM/TERMS/TERMSOFSALE.PHP](http://www.dtsfluidpower.com/terms/termsofsale.php). ADDITIONAL COPIES OF THE STANDARD TERMS AND CONDITIONS OF SALE ARE AVAILABLE ON REQUEST. ANY DIFFERENT OR ADDITIONAL TERMS AND CONDITIONS SET FORTH IN BUYER'S PURCHASE ORDER OR SIMILAR COMMUNICATIONS ARE OBJECTED TO AND SHALL NOT BE BINDING ON DTS FLUIDPOWER LLC UNLESS AGREED TO IN WRITING BY A DTS FLUIDPOWER LLC CORPORATE OFFICER.

Packing List Number: 30875348



PACKING LIST

Branch: GRANDVILLE
 3560 Busch Drive
 Grandville, MI 49418
 USA

Invoice Number	
30882558	
Invoice Date	Page
5/11/2017 13:30:12	1 of 1
Your PO Number	
056676	

Ship To:
ADVANCED FARM EQUIPMENT
5773 CRYSTAL ROAD
VESTABURG, MI 48891
US

Bill To: 17087
 ADVANCED FARM EQUIPMENT
 5773 CRYSTAL ROAD
 VESTABURG, MI 48891
 US
 877-287-5711

Ordered By: Kim Bollinger
 Customer ID: 104293

ORDER NUMBER	Terms Description	Net Due Date	Disc Due Date	Discount Amount
1688622	NET 30	6/10/2017	6/10/2017	

Order Date	Pick Ticket No	Primary Salesrep Name	Taker
3/20/2017 15:42:06	20896780	Scott. Drew	BBUCHOLTZ

Quantities			Item ID	Item Description
Ordered	Shipped	Remaining		
4.0000	4.0000	0.0000	DTS-34025	HOT OIL FLUSHING BLOCKS
1.0000	1.0000	0.0000	DTS-34022	FLUSH & BRAKE RELEASE, 2 SPEED SUPPLY
				FLUSH AND BRAKE RELEASE AND 2 SPEED SUPPLY MANIFOLD

Carrier: DELIVER Tracking #:

4.0000	✓ 4.0000	0.0000	DTS-34025	HOT OIL FLUSHING BLOCKS
1.0000	✓ 1.0000	0.0000	DTS-34022	FLUSH & BRAKE RELEASE, 2 SPEED SUPPLY
				FLUSH AND BRAKE RELEASE AND 2 SPEED SUPPLY MANIFOLD

Total Lines: 2
 Total Pieces: 5
 Total Weight: 0

RS

ALL SALES ARE EXPRESSLY SUBJECT TO DTS FLUIDPOWER LLC STANDARD TERMS AND CONDITIONS OF SALE, COPIES OF WHICH ARE FOUND ON OUR WEBSITE [HTTP://WWW.DTSFLUIDPOWER.COM/TERMS/TERMS_OF_SALE.PHP](http://www.dtsfluidpower.com/terms/terms_of_sale.php). ADDITIONAL COPIES OF THE STANDARD TERMS AND CONDITIONS OF SALE ARE AVAILABLE ON REQUEST. ANY DIFFERENT OR ADDITIONAL TERMS AND CONDITIONS SET FORTH IN BUYER'S PURCHASE ORDER OR SIMILAR COMMUNICATIONS ARE OBJECTED TO AND SHALL NOT BE BINDING ON DTS FLUIDPOWER LLC UNLESS AGREED TO IN WRITING BY A DTS FLUIDPOWER LLC CORPORATE OFFICER.

Packing List Number: 30882558



PACKING LIST

Branch: GRANDVILLE
 3560 Busch Drive
 Grandville, MI 49418
 USA

Invoice Number	
30882548	
Invoice Date	Page
5/11/2017 13:22:03	1 of 1
Your PO Number	
056676	

Ship To:

ADVANCED FARM EQUIPMENT
5773 CRYSTAL ROAD
VESTABURG, MI 48891
US

Bill To:

17087

ADVANCED FARM EQUIPMENT
 5773 CRYSTAL ROAD
 VESTABURG, MI 48891
 US
 877-287-5711

Ordered By: Kim Bollinger
 Customer ID: 104293

ORDER NUMBER		Terms Description	Net Due Date	Disc Due Date	Discount Amount
1688622		NET 30	6/10/2017	6/10/2017	
Order Date	Pick Ticket No	Primary Salesrep Name		Taker	
3/20/2017 15:42:06	20899445	Scott. Drew		BBUCHOLTZ	
Quantities			Item ID	Item Description	
Ordered	Shipped	Remaining			
1.0000	1.0000	0.0000	DTS-80169	4PD11 1.311- N11-CCH-DDH-CCH-DDH-LS	
Carrier: DELIVER			Tracking #:		

Total Lines: 1
 Total Pieces: 1
 Total Weight: 0

RS

ALL SALES ARE EXPRESSLY SUBJECT TO DTS FLUIDPOWER LLC STANDARD TERMS AND CONDITIONS OF SALE, COPIES OF WHICH ARE FOUND ON OUR WEBSITE [HTTP://WWW.DTSFLUIDPOWER.COM/TERMS/TERMS_OF_SALE.PHP](http://www.dtsfluidpower.com/terms/terms_of_sale.php). ADDITIONAL COPIES OF THE STANDARD TERMS AND CONDITIONS OF SALE ARE AVAILABLE ON REQUEST. ANY DIFFERENT OR ADDITIONAL TERMS AND CONDITIONS SET FORTH IN BUYER'S PURCHASE ORDER OR SIMILAR COMMUNICATIONS ARE OBJECTED TO AND SHALL NOT BE BINDING ON DTS FLUIDPOWER LLC UNLESS AGREED TO IN WRITING BY A DTS FLUIDPOWER LLC CORPORATE OFFICER.

Packing List Number: 30882548



PACKING LIST

Branch: GRANDVILLE
 3560 Busch Drive
 Grandville, MI 49418
 USA

Invoice Number	
30886155	
Invoice Date	Page
5/18/2017 11:52:49	1 of 1
Your PO Number	
056676	

Ship To:

ADVANCED FARM EQUIPMENT
5773 CRYSTAL ROAD
VESTABURG, MI 48891
US

Bill To:

17087
 ADVANCED FARM EQUIPMENT
 5773 CRYSTAL ROAD
 VESTABURG, MI 48891
 US
 877-287-5711

Ordered By: Kim Bollinger
 Customer ID: 104293

ORDER NUMBER	Terms Description	Net Due Date	Disc Due Date	Discount Amount
1688622	NET 30	6/17/2017	6/17/2017	

Order Date	Pick Ticket No	Primary Salesrep Name	Taker
3/20/2017 15:42:06	20901435	Scott. Drew	BBUCHOLTZ

Quantities			Item ID	Item Description
Ordered	Shipped	Remaining		

Carrier: DELIVER

Tracking #:

4.0000	4.0000	0.0000	DTS-30071	PRESSURE FILTER
			KHP04065	IA760.IKR-00550
2.0000	2.0000	0.0000	DTS-30072	PRESSURE FILTER
			IA760.IKR-00300	KHP05765

Total Lines: 2
 Total Pieces: 6
 Total Weight: 0

RS

ALL SALES ARE EXPRESSLY SUBJECT TO DTS FLUIDPOWER LLC STANDARD TERMS AND CONDITIONS OF SALE, COPIES OF WHICH ARE FOUND ON OUR WEBSITE [HTTP://WWW.DTSFLUIDPOWER.COM/TERMS/TERMSOFSALE.PHP](http://www.dtsfluidpower.com/terms/terms_of_sale.php). ADDITIONAL COPIES OF THE STANDARD TERMS AND CONDITIONS OF SALE ARE AVAILABLE ON REQUEST. ANY DIFFERENT OR ADDITIONAL TERMS AND CONDITIONS SET FORTH IN BUYER'S PURCHASE ORDER OR SIMILAR COMMUNICATIONS ARE OBJECTED TO AND SHALL NOT BE BINDING ON DTS FLUIDPOWER LLC UNLESS AGREED TO IN WRITING BY A DTS FLUIDPOWER LLC CORPORATE OFFICER.

Packing List Number: 30886155



PACKING LIST

Branch: GRANDVILLE
 3560 Busch Drive
 Grandville, MI 49418
 USA

Invoice Number	
30886151	
Invoice Date	Page
5/18/2017 11:50:06	1 of 1
Your PO Number	
056676	

Ship To:

ADVANCED FARM EQUIPMENT
5773 CRYSTAL ROAD
VESTABURG, MI 48891
US

Bill To:

17087

ADVANCED FARM EQUIPMENT
 5773 CRYSTAL ROAD
 VESTABURG, MI 48891
 US
 877-287-5711

Ordered By: Kim Bollinger

Customer ID: 104293

ORDER NUMBER	Terms Description	Net Due Date	Disc Due Date	Discount Amount
1688622	NET 30	6/17/2017	6/17/2017	
Order Date	Pick Ticket No	Primary Salesrep Name		Taker
3/20/2017 15:42:06	20895031	Scott. Drew		BBUCHOLTZ
Quantities			Item ID	Item Description
Ordered	Shipped	Remaining		
1.0000	<u>1.0000</u>	0.0000	DTS-80200	3 STATION D03 PACKER, REAR STEERING

Carrier: DELIVER

Tracking #:

1.0000

1.0000

0.0000

DTS-80200

3 STATION D03 PACKER, REAR STEERING

Total Lines: 1
 Total Pieces: 1
 Total Weight: 0

RS

ALL SALES ARE EXPRESSLY SUBJECT TO DTS FLUIDPOWER LLC STANDARD TERMS AND CONDITIONS OF SALE, COPIES OF WHICH ARE FOUND ON OUR WEBSITE [HTTP://WWW.DTSFLUIDPOWER.COM/TERMS/TERMSOFSALE.PHP](http://www.dtsfluidpower.com/terms/termsofsale.php). ADDITIONAL COPIES OF THE STANDARD TERMS AND CONDITIONS OF SALE ARE AVAILABLE ON REQUEST. ANY DIFFERENT OR ADDITIONAL TERMS AND CONDITIONS SET FORTH IN BUYER'S PURCHASE ORDER OR SIMILAR COMMUNICATIONS ARE OBJECTED TO AND SHALL NOT BE BINDING ON DTS FLUIDPOWER LLC UNLESS AGREED TO IN WRITING BY A DTS FLUIDPOWER LLC CORPORATE OFFICER.

Packing List Number: 30886151



Branch: GRANDVILLE
 3560 Busch Drive
 Grandville, MI 49418
 USA

PACKING LIST

Invoice Number	
30893447	
Invoice Date	Page
6/1/2017 18:13:59	1 of 1
Your PO Number	
056676	

Ship To:

ADVANCED FARM EQUIPMENT
5773 CRYSTAL ROAD
VESTABURG, MI 48891
US

Bill To:

ADVANCED FARM EQUIPMENT
 5773 CRYSTAL ROAD
 VESTABURG, MI 48891
 US
 877-287-5711

17087

Ordered By: Kim Bollinger
 Customer ID: 104293

ORDER NUMBER	Terms Description	Net Due Date	Disc Due Date	Discount Amount
1688622	NET 30	7/1/2017	7/1/2017	

Order Date	Pick Ticket No	Primary Salesrep Name	Taker
3/20/2017 15:42:06	20907212	Scott. Drew	BBUCHOLTZ

Quantities			Item ID	Item Description
Ordered	Shipped	Remaining		
3.0000	1.0000	2.0000	BTL5-T-2814-1S	BAM01FC CAPTIVE MAGNET

Carrier: DELIVER

Tracking #:

3.0000

1.0000

2.0000

BTL5-T-2814-1S

BAM01FC CAPTIVE MAGNET

Customer Part No: 2022-0373

Total Lines: 1
 Total Pieces: 1
 Total Weight: 0

RS

ALL SALES ARE EXPRESSLY SUBJECT TO DTS FLUIDPOWER LLC STANDARD TERMS AND CONDITIONS OF SALE, COPIES OF WHICH ARE FOUND ON OUR WEBSITE [HTTP://WWW.DTSFLUIDPOWER.COM/TERMS/TERMS_OF_SALE.PHP](http://www.dtsfluidpower.com/terms/terms_of_sale.php). ADDITIONAL COPIES OF THE STANDARD TERMS AND CONDITIONS OF SALE ARE AVAILABLE ON REQUEST. ANY DIFFERENT OR ADDITIONAL TERMS AND CONDITIONS SET FORTH IN BUYER'S PURCHASE ORDER OR SIMILAR COMMUNICATIONS ARE OBJECTED TO AND SHALL NOT BE BINDING ON DTS FLUIDPOWER LLC UNLESS AGREED TO IN WRITING BY A DTS FLUIDPOWER LLC CORPORATE OFFICER.

Packing List Number: 30893447



PACKING LIST

Branch: GRANDVILLE
 3560 Busch Drive
 Grandville, MI 49418
 USA

Invoice Number	
30893449	
Invoice Date	Page
6/1/2017 18:14:39	1 of 1
Your PO Number	
056676	

Ship To:

ADVANCED FARM EQUIPMENT
5773 CRYSTAL ROAD
VESTABURG, MI 48891
US

Bill To:

ADVANCED FARM EQUIPMENT
 5773 CRYSTAL ROAD
 VESTABURG, MI 48891
 US
 877-287-5711

17087

Ordered By: Kim Bollinger
 Customer ID: 104293

ORDER NUMBER	Terms Description	Net Due Date	Disc Due Date	Discount Amount
1688622	NET 30	7/1/2017	7/1/2017	
Order Date	Pick Ticket No	Primary Salesrep Name		Taker
3/20/2017 15:42:06	20907974	Scott. Drew		BBUCHOLTZ
Quantities			Item ID	Item Description
Ordered	Shipped	Remaining		
3.0000	2.0000	0.0000	BTL5-T-2814-1S	BAM01FC CAPTIVE MAGNET
Carrier: DELIVER		Tracking #:		
		Customer Part No: 2022-0373		

Total Lines: 1
 Total Pieces: 2
 Total Weight: 0

RS

ALL SALES ARE EXPRESSLY SUBJECT TO DTS FLUIDPOWER LLC STANDARD TERMS AND CONDITIONS OF SALE, COPIES OF WHICH ARE FOUND ON OUR WEBSITE [HTTP://WWW.DTSFLUIDPOWER.COM/TERMS/TERMSOFSALE.PHP](http://www.dtsfluidpower.com/terms/terms_of_sale.php). ADDITIONAL COPIES OF THE STANDARD TERMS AND CONDITIONS OF SALE ARE AVAILABLE ON REQUEST. ANY DIFFERENT OR ADDITIONAL TERMS AND CONDITIONS SET FORTH IN BUYER'S PURCHASE ORDER OR SIMILAR COMMUNICATIONS ARE OBJECTED TO AND SHALL NOT BE BINDING ON DTS FLUIDPOWER LLC UNLESS AGREED TO IN WRITING BY A DTS FLUIDPOWER LLC CORPORATE OFFICER.



Branch: GRANDVILLE
 3560 Busch Drive
 Grandville, MI 49418
 USA

PACKING LIST

Invoice Number	
30893450	
	
Invoice Date	Page
6/1/2017 18:15:02	1 of 1
Your PO Number	
056676	

17087

Ship To:

ADVANCED FARM EQUIPMENT
5773 CRYSTAL ROAD
VESTABURG, MI 48891
US

Bill To:

ADVANCED FARM EQUIPMENT
 5773 CRYSTAL ROAD
 VESTABURG, MI 48891
 US
 877-287-5711

Ordered By: Kim Bollinger
 Customer ID: 104293

ORDER NUMBER	Terms Description	Net Due Date	Disc Due Date	Discount Amount
1688622	NET 30	7/1/2017	7/1/2017	
Order Date	Pick Ticket No	Primary Salesrep Name		Taker
3/20/2017 15:42:06	20907081	Scott. Drew		BBUCHOLTZ
Quantities			Item ID	Item Description
Ordered	Shipped	Remaining		
3.0000	3.0000	0.0000	ZQK/S	T-3 A STEEL BODY
Carrier: DELIVER			Tracking #:	

Total Lines: 1
 Total Pieces: 3
 Total Weight: 0

RS

ALL SALES ARE EXPRESSLY SUBJECT TO DTS FLUIDPOWER LLC STANDARD TERMS AND CONDITIONS OF SALE, COPIES OF WHICH ARE FOUND ON OUR WEBSITE [HTTP://WWW.DTSFLUIDPOWER.COM/TERMS/TERMSOFSALE.PHP](http://www.dtsfluidpower.com/terms/termsofsale.php). ADDITIONAL COPIES OF THE STANDARD TERMS AND CONDITIONS OF SALE ARE AVAILABLE ON REQUEST. ANY DIFFERENT OR ADDITIONAL TERMS AND CONDITIONS SET FORTH IN BUYER'S PURCHASE ORDER OR SIMILAR COMMUNICATIONS ARE OBJECTED TO AND SHALL NOT BE BINDING ON DTS FLUIDPOWER LLC UNLESS AGREED TO IN WRITING BY A DTS FLUIDPOWER LLC CORPORATE OFFICER.

Packing List Number: 30893450



Branch: GRANDVILLE
 3560 Busch Drive
 Grandville, MI 49418
 USA

PACKING LIST

Invoice Number	
30896924	
Invoice Date	Page
6/8/2017 17:26:11	1 of 1
Your PO Number	
056676	

Ship To:

ADVANCED FARM EQUIPMENT
5773 CRYSTAL ROAD
VESTABURG, MI 48891
US

Bill To:

17087
 ADVANCED FARM EQUIPMENT
 5773 CRYSTAL ROAD
 VESTABURG, MI 48891
 US
 877-287-5711

Ordered By: Kim Bollinger
 Customer ID: 104293

ORDER NUMBER	Terms Description	Net Due Date	Disc Due Date	Discount Amount
1688622	NET 30	7/8/2017	7/8/2017	

Order Date	Pick Ticket No	Primary Salesrep Name	Taker
3/20/2017 15:42:06	20911656	Scott. Drew	BBUCHOLTZ

Quantities			Item ID
Ordered	Shipped	Remaining	Item Description

Carrier: DELIVER

Tracking #:

3.0000 *2.0000* 1.0000 BTL6-E500-M0457-PF-S115
 TRANSDUCER
 Customer Part No: 2022-0372

3.0000 *2.0000* 1.0000 BTL2-GS10-0305-A
 CONTROL ARM, 305MM
 Customer Part No: 2022-0400

Total Lines: 2
 Total Pieces: 4
 Total Weight: 0

RS

ALL SALES ARE EXPRESSLY SUBJECT TO DTS FLUIDPOWER LLC STANDARD TERMS AND CONDITIONS OF SALE, COPIES OF WHICH ARE FOUND ON OUR WEBSITE [HTTP://WWW.DTSFLUIDPOWER.COM/TERMS/TERMSOFSALE.PHP](http://www.dtsfluidpower.com/terms/terms_of_sale.php). ADDITIONAL COPIES OF THE STANDARD TERMS AND CONDITIONS OF SALE ARE AVAILABLE ON REQUEST. ANY DIFFERENT OR ADDITIONAL TERMS AND CONDITIONS SET FORTH IN BUYER'S PURCHASE ORDER OR SIMILAR COMMUNICATIONS ARE OBJECTED TO AND SHALL NOT BE BINDING ON DTS FLUIDPOWER LLC UNLESS AGREED TO IN WRITING BY A DTS FLUIDPOWER LLC CORPORATE OFFICER.

Packing List Number: 30896924



PACKING LIST

Branch: GRANDVILLE
 3560 Busch Drive
 Grandville, MI 49418
 USA

Invoice Number	
30896925	
Invoice Date	Page
6/8/2017 17:26:40	1 of 1
Your PO Number	
056676	

Ship To:

ADVANCED FARM EQUIPMENT
5773 CRYSTAL ROAD
VESTABURG, MI 48891
US

Bill To:

17087
 ADVANCED FARM EQUIPMENT
 5773 CRYSTAL ROAD
 VESTABURG, MI 48891
 US
 877-287-5711

Ordered By: Kim Bollinger
 Customer ID: 104293

ORDER NUMBER	Terms Description	Net Due Date	Disc Due Date	Discount Amount
1688622	NET 30	7/8/2017	7/8/2017	

Order Date	Pick Ticket No	Primary Salesrep Name	Taker
3/20/2017 15:42:06	20910974	Scott. Drew	BBUCHOLTZ

Quantities			Item ID	Item Description
Ordered	Shipped	Remaining		

Carrier: DELIVER

Tracking #:

3.0000 *✓* 1.0000 0.0000 BTL6-E500-M0457-PF-S115
 TRANSDUCER

Customer Part No: 2022-0372

3.0000 *✓* 1.0000 0.0000 BTL2-GS10-0305-A
 CONTROL ARM, 305MM

Customer Part No: 2022-0400

Total Lines: 2
 Total Pieces: 2
 Total Weight: 0

RS

ALL SALES ARE EXPRESSLY SUBJECT TO DTS FLUIDPOWER LLC STANDARD TERMS AND CONDITIONS OF SALE, COPIES OF WHICH ARE FOUND ON OUR WEBSITE [HTTP://WWW.DTSFLUIDPOWER.COM/TERMS/TERMSOFSALE.PHP](http://www.dtsfluidpower.com/terms/termsofsale.php). ADDITIONAL COPIES OF THE STANDARD TERMS AND CONDITIONS OF SALE ARE AVAILABLE ON REQUEST. ANY DIFFERENT OR ADDITIONAL TERMS AND CONDITIONS SET FORTH IN BUYER'S PURCHASE ORDER OR SIMILAR COMMUNICATIONS ARE OBJECTED TO AND SHALL NOT BE BINDING ON DTS FLUIDPOWER LLC UNLESS AGREED TO IN WRITING BY A DTS FLUIDPOWER LLC CORPORATE OFFICER.

Packing List Number: 30896925

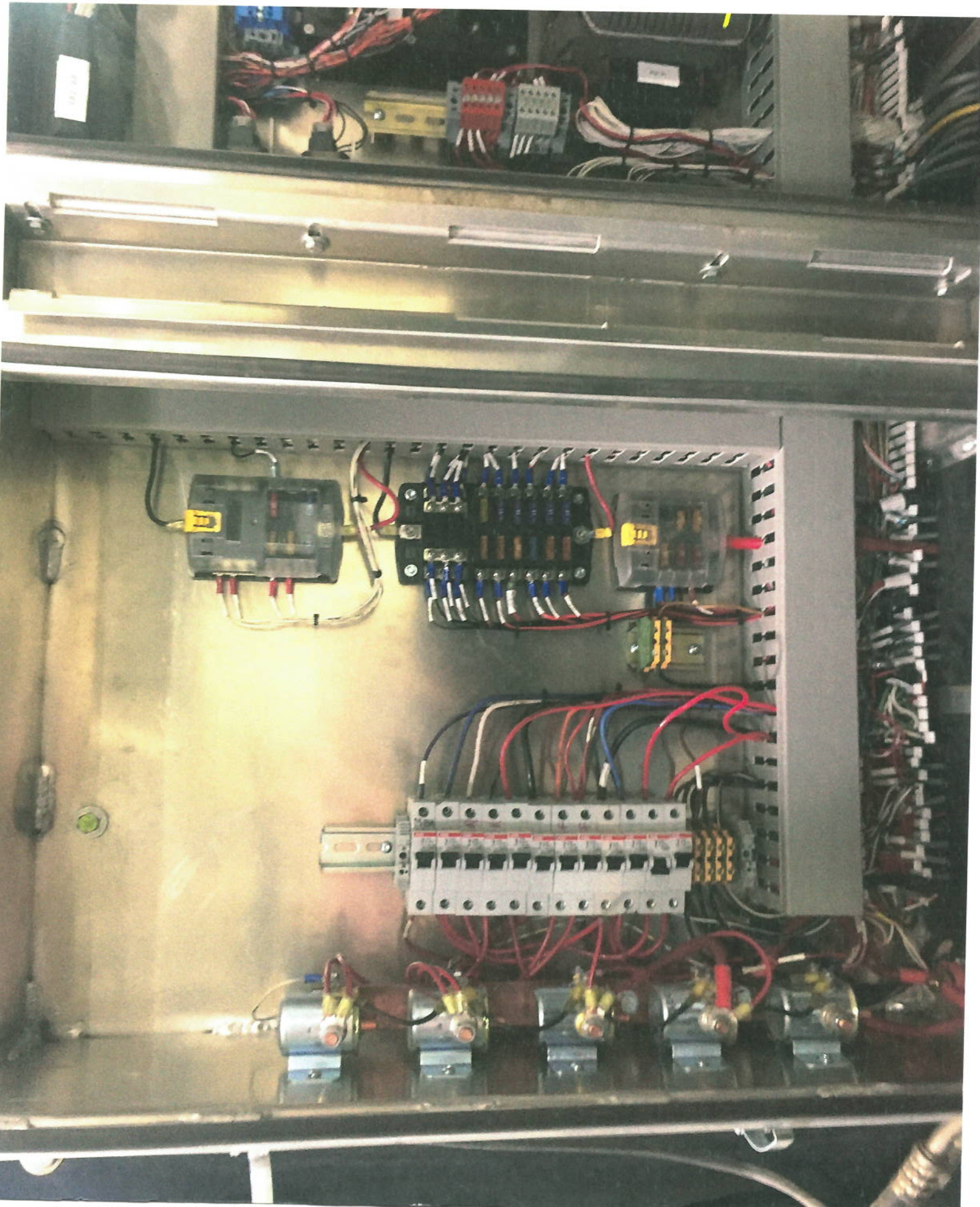

Horizontal Applications

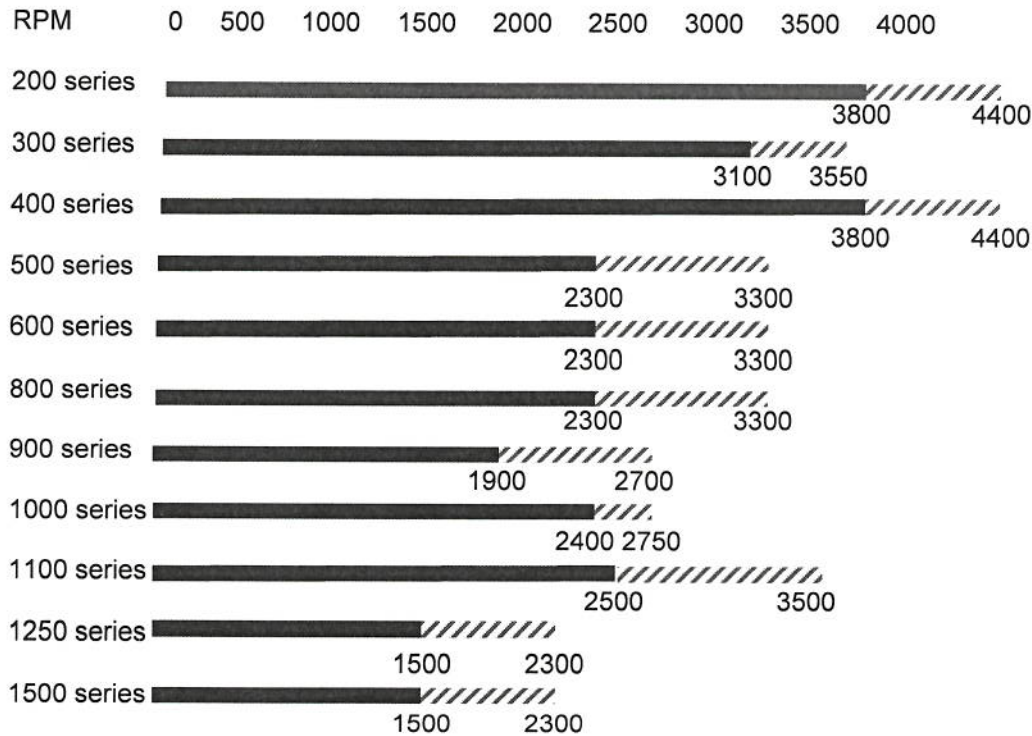

█ = Use grease ▨ = consult factory for lubrication requirements

Grease capacity

	Minimum	Maximum		Minimum	Maximum
200 series	.5 oz.	1.0 oz.	900 series	4.3 oz.	8.6 oz.
300 series	.7 oz.	1.4 oz.	1000 series*	13.0 oz.	15.0 oz.
400 series	.4 oz.	1.0 oz.	1100 series*	13.0 oz.	15.0 oz.
500 series	2.0 oz.	4.0 oz.	1250 series	11.0 oz.	22.0 oz.
600 series	2.2 oz.	4.4 oz.	1500 series	11.0 oz.	22.0 oz.
800 series	2.8 oz.	5.6 oz.			

* Per grease fitting (There are 2 fittings on the 1000 and 1100 series units so the total grease is 2 times the amounts given in the above chart)

Caution – exceeding the maximum grease capacity will result in overheating of the bearing and reduced operating life

Grease type.

Indoor conditions	High Quality NLGI #1 or NLGI #2
Outdoor conditions	High Quality NLGI #1 or NLGI #2 (Synthetic grease recommended)
Severe conditions	consult factory

For applications where the shaft is vertical - consult factory for special bearing and lubrication

Project: _____ Date: _____

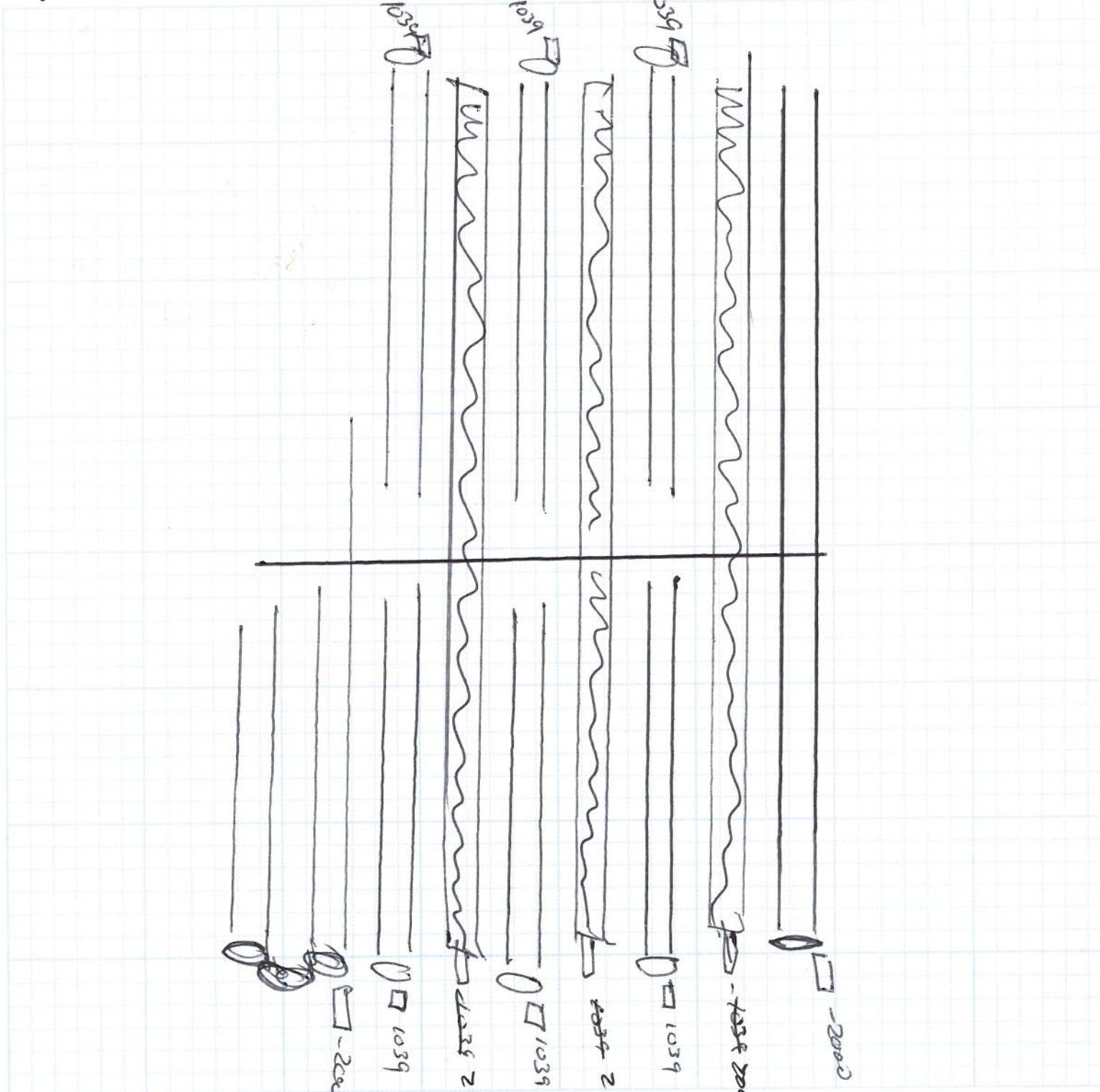

- Pneumatics & Fluid Control
- Industrial Hydraulics & Lubrication
- Motion Control & Automation
- Mobile Products
- Engineered Systems

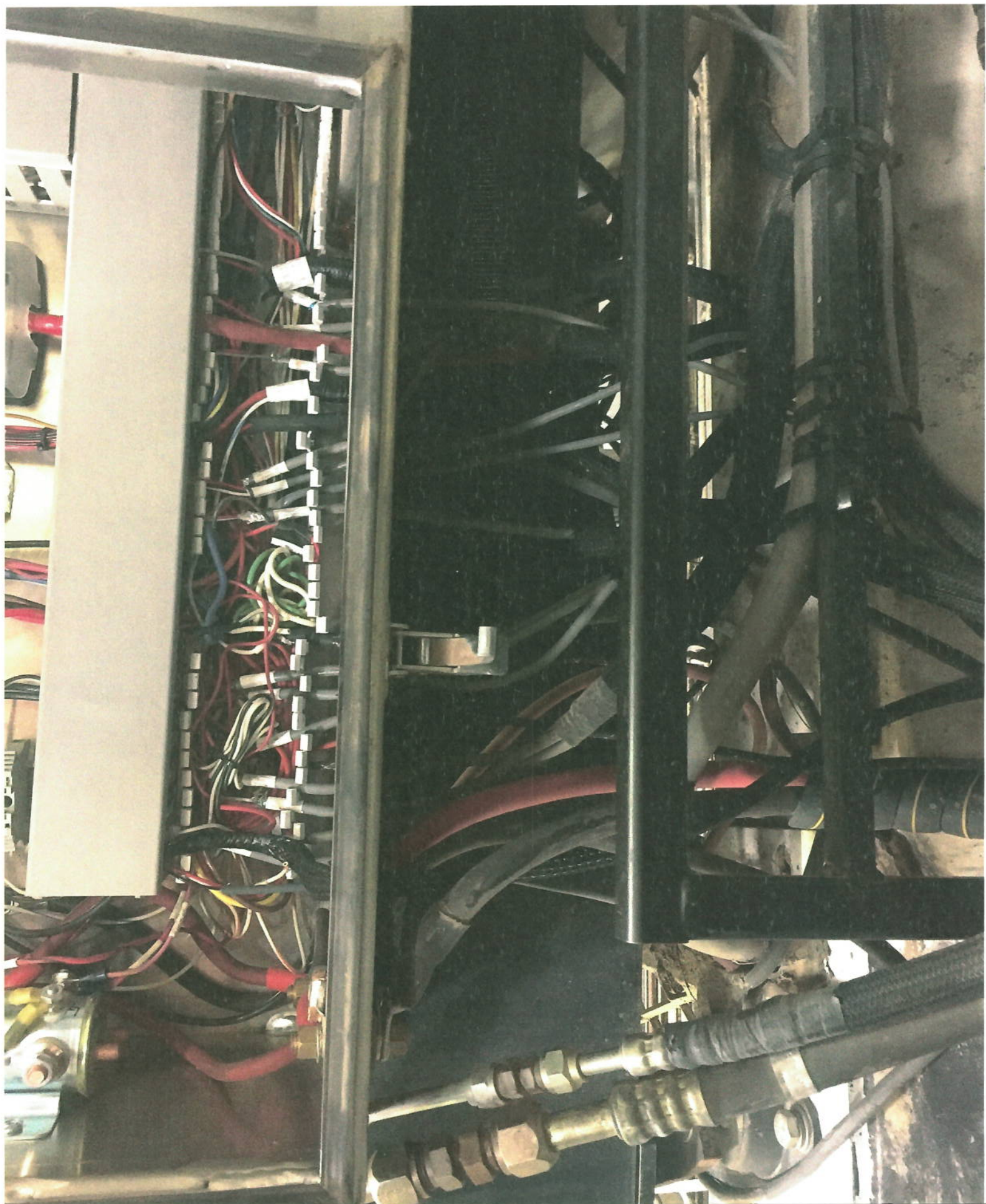



Anchor Fluid Power
 5553 Murray Road
 Cincinnati, OH 45227
 Phone: 513.527.4444 • Fax: 513.527.4449
 Email: sales@anchorfluidpower.com

CD61/CD62 BOLT PATTERN ADAPTERS

Outer envelope shape may vary due to size configuration.

Mounting kit available on o-ring grooved flanges

Please see below for Ordering Information and click 'Request Quote' or 'Request Information' to configure your Bolt Pattern Adapter.

List Price -

QUOTE



SPECIFICATIONS

AFA - 1261 - 3262

Ordering Information

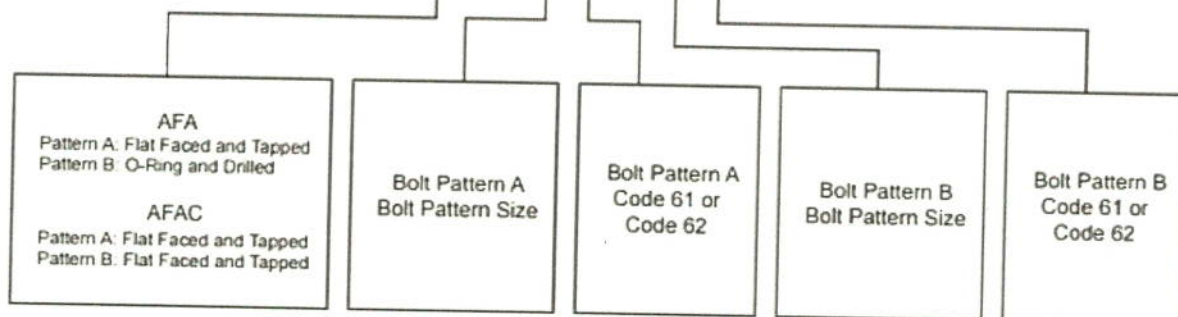

CD6162-Bolt-Pattern-Adapters-Order-Info-2

**Dimension
Drawing**

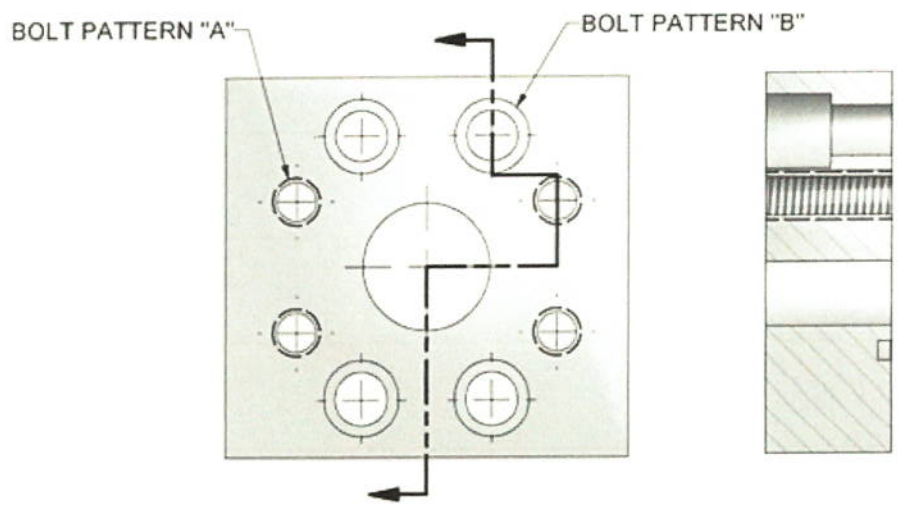

CD61/CD62 Bolt Pattern Adapters

General Information

SPLIT FLANGE CLAMP

Clean the sealing surfaces and make certain they are free from nicks, scratches and burrs. Foreign material prevents a proper seal.

Lubricate the o-ring and ensure that it is properly installed as to prevent damage during installation.

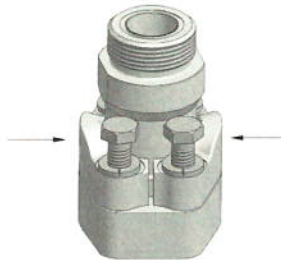

Push the flange clamps towards the flange head and screw fasteners into flange pad. Continue to screw the fasteners until their heads just meet the split flange surface.



Torque the fasteners in diagonal sequence, in small increments, until final torque level is achieved. Torque values for flange connections listed above. Notice that the torque values vary according to size and fastener type.

Anchor Fluid Power split flange connections are manufactured according to SAE J518-1 and -2; as well as ISO 6162-1 and -2. These standards control dimensions, tolerances and plating. Please note that the above pressure rating chart refers to the flange connection. Adapting the flange to other connections, such as braze tube, welded pipe, or threaded ports / stud ends, could reduce maximum working pressure.

Please consult with Anchor Fluid Power for pressure rating specific to your connection requirement.

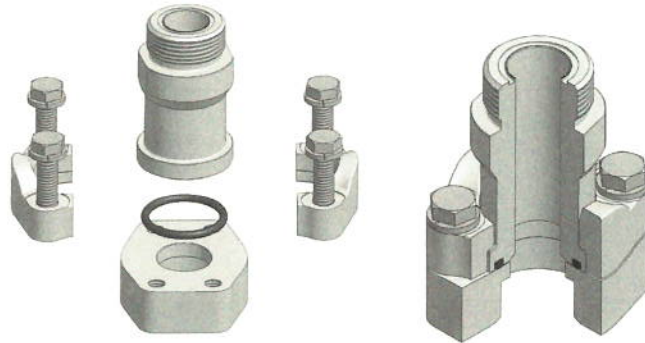

PRESSURE RATINGS OF SAE FLANGES

CODE 61 SAE J518-1 / ISO 6162-1					
DASH SIZE	INCH SIZE	MAX WORKING PRESSURE		GRADE 8 AND EQUIVALENT FASTENER TORQUE VALUE	
		PSI	MPA	SOCKET HEAD UNC (LB-FT)	HEX HEAD UNC (LB-FT)
-8	1/2"	5000	35	24	18
-12	3/4"	5000	35	44	33
-16	1"	4600	32	44	33
-20	1 1/4"	4000	28	68	52
-24	1 1/2"	3000	21	111	80
-32	2"	3000	21	111	80
-40	2 1/2"	2500	17.5	111	80
-48	3"	2300	16	218	160
-56	3 1/2"	500	3.5	218	160
-64	4"	500	3.5	218	160
-80	5"	500	3.5	218	160

CODE 62 SAE J518-2 / ISO 6162-2					
DASH SIZE	INCH SIZE	MAX WORKING PRESSURE		GRADE 8 AND EQUIVALENT FASTENER TORQUE VALUE	
		PSI	MPA	SOCKET HEAD UNC (LB-FT)	HEX HEAD UNC (LB-FT)
-8	1/2"	6000	40	24	18
-12	3/4"	6000	40	44	33
-16	1"	6000	40	68	52
-20	1 1/4"	6000	40	111	80
-24	1 1/2"	6000	40	218	160
-32	2"	6000	40	332	281
-40	2 1/2"	6000	40	N/A	605
-48	3"	6000	40	N/A	1280

**All max working pressures listed above are specific to the SAE J518/ISO 6162 bolt pattern. Features within the 4-Bolt flange and the connection opposite the 4-Bolt flange can de-rate the maximum working pressure.

NOTE - All carbon steel torque values are based on AFP supplied socket head and hex head fasteners. Use of alternate fasteners can affect torque value. Consult factory for additional information.

8 - AFA - 2062 - 2462

DTS - ILLINOIS
2240 LANDMEIER ROAD
ELK GROVE VILLAGE, IL 60007
PH: 847-758-1705
FAX: 847-758-1710

DTS - HEADQUARTERS
3560 BUSCH DRIVE
GRANDVILLE, MI 49418
PH: 616-538-3759
FAX: 616-538-3798

DTS - MADISON HEIGHTS
31731 SHERMAN DRIVE
MADISON HEIGHTS, MI 48071
PH: 248-585-9500
FAX: 248-585-0855

QTY	PART NO	DESCRIPTION
12	SFXK-24-24	
25	SFXK-20	
4	SFK-16	
2	NB6842-16-12	
25	500454-16-16	
5	NB6890-12-16	
4	NB6890-16-16	
5	NB6892-16-12	



Alro Steel

the Alro Team

- Alro Steel
- Alro Metals Service Center
- Alro Industrial Supply
- Alro Plastics
- Alro Metals Plus

049593 HYD
049594 ELECTRICAL

REAR GROUND DRIVE MANIFOLD

A & B 4 PORTS 1 1/2" CODE 62

2 FILTERS 4 PORTS 1 1/2" CODE 62

8 - 1 1/2" CODE 62 X 1 1/2" HOSE

EACH PARKER PUMP 1 1/4" CODE 62 2 PORTS EACH

TOTAL = 4 PORTS

4 - 1 1/4" CODE 62 X 1 1/2" HOSE

REAR G.D. TO REAR MANIFOLD

4 - 1 1/4" CODE 62 45°

4 - 1 1/4" CODE 62 - WHAT ANGLE @ MANIFOLD?

FRONT G.D. TO FRONT MANIFOLD

4 - 1" CODE 62 45°

4 - 1" CODE 62 - WHAT ANGLE @ MANIFOLD?

REAR MANIFOLD TO FRONT MANIFOLD

4 - 1 1/4" CODE 62 X 1 1/2" HOSE

- WHAT ANGLE @ MANIFOLD?

REAR OF HARVESTER →

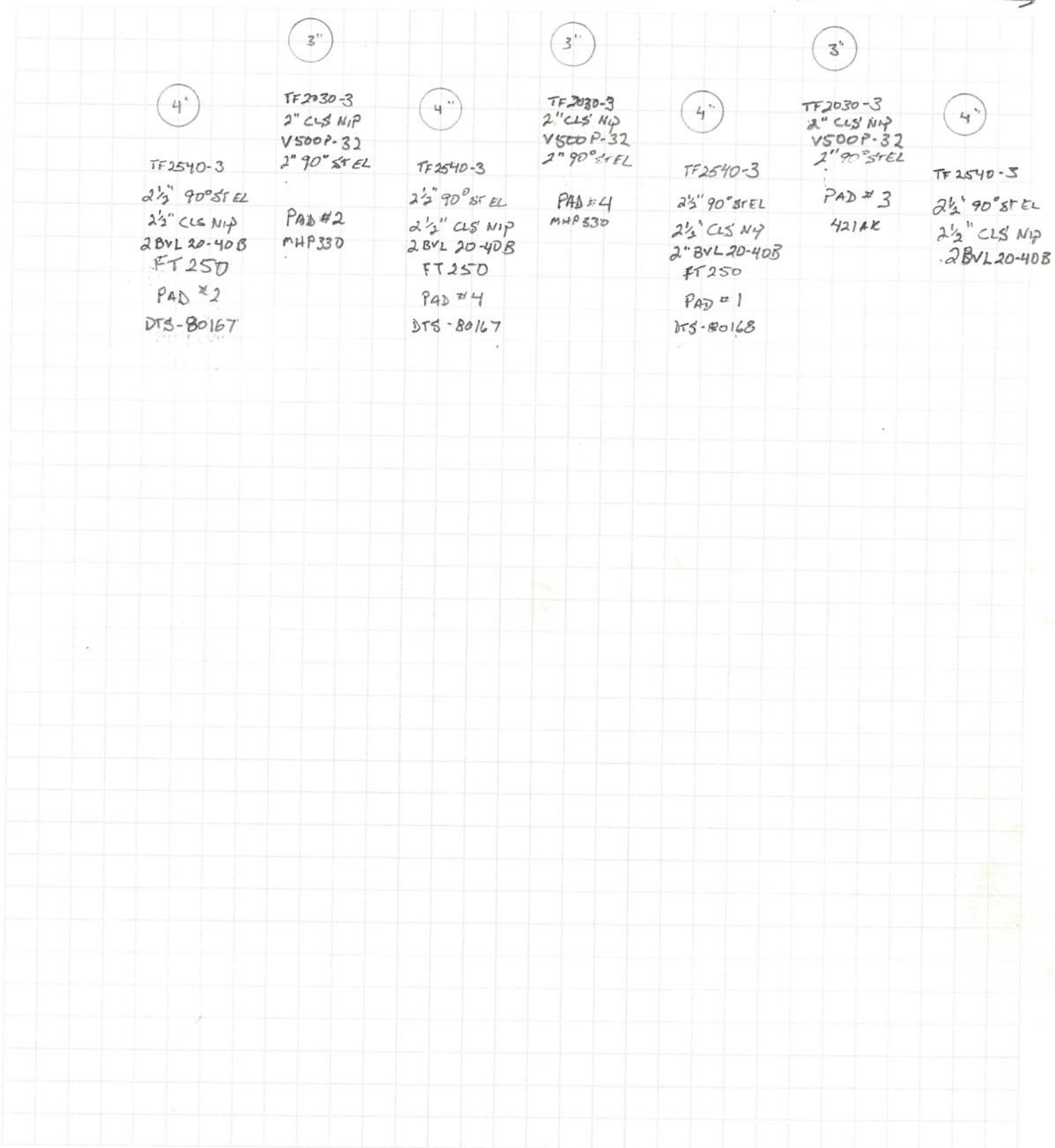

DTS - ILLINOIS
 2240 LANDMEIER ROAD
 ELK GROVE VILLAGE, IL 60007
 PH: 847-758-1705
 FAX: 847-758-1710

DTS - HEADQUARTERS
 3560 BUSCH DRIVE
 GRANDVILLE, MI 49418
 PH: 616-538-3759
 FAX: 616-538-3798

DTS - MADISON HEIGHTS
 31731 SHERMAN DRIVE
 MADISON HEIGHTS, MI 48071
 PH: 248-585-9500
 FAX: 248-585-0855

Contents:

- 1 Aluminium Box
- 2 Switch Console For Potato Digger
- 3 MD4-10 Screen
- 4 MD4-10 Screen Mount
- 5 4 MC43 plus Connectors
- 6 3 G11 Modules
- 7 5 XC23 Modules
- 8 Address Tags
- 9 4 mVAC Modules

STAHLS
BOX'S
CONTENTS

Contents:

- 1 Aluminum Box
- 2 2 Hydraulic Valves for Steering

STAIRS
BOXES
CONTENTS

