

#16081

Integrity AG

4RSRH w/65" AH

| | | | | | | | | | | |
|------------------------|--------------------------|---------------------|---------------------------|----------------------------|---------------------------------|---------------------|-------------------------|-----------------------------|------------------------------|---|
| 0 | 0 | 0 | 0 | 0 | 0 | 0 | 0 | 0 | 0 | 0 |
| PRIMARY CHARGE 600# | SECONDARY CHARGE 600# | AIRHEAD 10,000# | AIRHEAD CHARGE 600# | BRAKE CHARGE 1000# | STEERING 3,000# | AIR KNIFE 5,000# | GROUND DRIVE 10,000# | GROUND DRIVE CHARGE 600# | MOTOR DISPLACEMENT 1,000# | |
| 0 | 0 | 0 | 0 | 0 | 0 | 0 | 0 | 0 | 0 | |
| LEFT PRIMARY 5,000# | RIGHT PRIMARY 5,000# | SECONDARY 5,000# | LEFT STAR ROLLS 3,000# | RIGHT STAR ROLLS 3,000# | RIGHT STAR DIST ROLLS 3,000# | CROSS 3,000# | AIRHEAD FEED 3,000# | AIRHEAD DISCHARGE 3,000# | BIN UNLOAD 3,000# | |

4RSPH65LAH (7)

PLUG #1
PIN #

| | | | | |
|----|--------|------|--|----------|
| 1 | Yellow | 92 | CB 1 To Hazard Stat Switch | |
| 2 | Green | 91 | CB 2 To Airhead Cleaner / Bin Fill / Star Table Reverse Switches | |
| 3 | Orange | 090 | Reset Switch To Reset Relay | |
| 4 | Black | 017 | CB 4 To Brake Warning | |
| 5 | Red | 081 | CB 10 To Fuel Pump Switch | |
| 6 | Yellow | 089 | Reset Switch To Reset Relay | |
| 7 | Yellow | 116 | Coulter Switch Up To Junction Panel | |
| 8 | Brown | 117 | Coulter Switch Down To MV5 Valve | |
| 9 | Black | 0017 | Brake Switch To Brake Solenoid | Black 17 |
| 10 | Brown | 88 | CB 11 To Backup / Strobe / Road Lights Switches | |
| 11 | White | 85 | CB 12 To Actuator Switches | |
| 12 | Red | 81 | Fuel Pump Switch To Fuel Pump | |
| 13 | Purple | 28 | Airhead Cleaner Auto To Timer #10 | |
| 14 | White | 27 | Airhead Cleaner Manual To Timer #9 To Solenoid | |
| 15 | Blue | 26 | Airhead Cleaner Manual To Timer #8 To solenoid | |
| 16 | Brown | 46 | Stripper MV5 Valve Down | |
| 17 | Green | 45 | Stripper MV5 Valve Up | |
| 18 | Red | 029 | Strobe Lights Switch To Relay | |
| 19 | Yellow | 33 | Shaker MV5 Valve Down | |
| 20 | Red | 32 | Shaker MV5 Valve Up | |
| 21 | Red | 70 | Airhead Feed RDRS112-30 Actuator | |
| 22 | Purple | 69 | Airhead Feed RDRS112-30 Actuator | |
| 23 | Red | 52 | CB 14 To Foot Switches - 12VDC . | |
| 24 | Purple | 83 | Foot Switches To Steering Box | |
| 25 | Blue | 55 | Left Crab Foot Switch To Steering Box Relay | |
| 26 | Black | 804 | Seat Switch To Time Delay Relay Pin 6 ✕ | |
| 27 | Black | 810 | Seat Switch To Time Delay Relay Pin 7 ✕ | |
| 28 | Red | 052 | #9 Auxillary CB To Truck Lights Foor Plate | |
| 29 | Brown | 37 | Right Star Table RDRS112-30 Actuator | |
| 30 | Green | 38 | Right Star Table RDRS112-30 Actuator | |
| 31 | Orange | 56 | Right Crab Foot Switch To steering Box Relay | |
| 32 | Yellow | 42 | Bin Fill Switch To RDRS112-30 Actuator | |
| 33 | White | 43 | Bin Fill Switch To RDRS112-30 Actuator | |
| 34 | Red | 028 | Auxiliary Power Outlet Pin 2 In Panel To Airhead / Trash Fan Switches - On/Off | |
| 35 | White | 65 | Left Star Table Switch To RDRS112-30 Actuator | |
| 36 | Purple | 66 | Left Star Table Switch To RDRS112-30 Actuator | |
| 37 | Orange | 50 | Bin Unload Bypass SV3-16-0-12T-12DG Solenoid | |

16081

Integrity Ag.

5/1/2016

4RSPH65LAH (7)

PLUG 2
PIN #

| | | | | |
|----|--------|-----|---|------------|
| 1 | Brown | 153 | Left Primary Reverse | |
| 2 | Orange | 154 | Right Primary Reverse | |
| 3 | Black | 059 | Park Switch To 14(5) / 15(5) Red 0015 To Xm To SV4-10-0 | |
| 4 | Yellow | 752 | Hydraulic Oil Temperature Sender - Gray-Pin A- To Cab | Yellow 752 |
| 5 | Yellow | 753 | Hydraulic Oil Temperature Sender - Violet-Pin B- To Cab | Yellow 753 |
| 6 | Green | 155 | Secondary Reverse | |
| 7 | Brown | 54 | Right Turn /Signal | |
| 8 | Yellow | 53 | Left Tun Signal | |
| 9 | Brown | 06 | Back-Up Light Switch To Relay | |
| 10 | Brown | 505 | Right Work Light Switch To Relay | Brown 505 |
| 11 | Green | 437 | Primary Circuit Temperature Sender - Violet - Pin B- To Cab | Green 437 |
| 12 | Black | 01 | 4X4 Switch To XA2 Module C1:21 | |
| 13 | Black | 12 | 2-Speed Switch To XA2 - C1:16 | |
| 14 | | | | |
| 15 | Brown | 11 | Airhead Discharge Switch To DTS-0373B(A) Solenoid | |
| 16 | Yellow | 5 | Airhead Feed Switch To DTS-0373B(A) Solenoid | |
| 17 | Brown | 16 | Cross Conveyor Switch To DTS-0373B(A) Solenoid | |
| 18 | Red | 82 | Star Table Table Switch To 3 DTS-0373B(B) Solenoid's | |
| 19 | Yellow | 156 | Left Primary Forward | |
| 20 | Yellow | 15 | Fan Return Filter #3 To Light | |
| 21 | Blue | 3 | Ground Drive Hi-Pressure Filter #3 To Light | |
| 22 | Yellow | 20 | Hydraulic level Sensor To Cab (BZL-13) | |
| 23 | White | 61 | Cross Pressure Switch To Cab BZ6562 | |
| 24 | Black | 22 | Boom Switch To DTS-0373B Solenoid | |
| 25 | | | | |
| 26 | | | | |
| 27 | Red | 157 | Right Primary Forward | |
| 28 | Purple | 094 | Road Light Switch To Road light Relay | |
| 29 | Red | 149 | Steel Rolls Switch To RDRS112-30 Actuator | |
| 30 | Yellow | 150 | Steel Rolls Switch To RDRS112-30 Actuator | |
| 31 | Orange | 145 | Star Distributor Rolls Switch To RDRS112-30 Actuator | |
| 32 | Blue | 146 | Star Distributor Rolls Switch To RDRS112-30 Actuator | |
| 33 | Orange | 147 | Hump Shaft Actuator | |
| 34 | Blue | 148 | Hump Shaft Actuator | |
| 35 | Black | 151 | Steel Roll Spacing Actuator | |
| 36 | Green | 425 | Primary Circuit Temperature Sender - Gray-Pin A- To Cab | Green 425 |
| 37 | Red | 152 | Steel Roll Spacing Actuator | |

16081

Integrity Ag.

5/1/2016

4RSPH65LAH (7)

PLUG 3

PIN

| | | | | |
|-----|--------|-------|--|----------|
| | | | | P |
| *1 | Red | 18 | CB 6 Wiper Power | 2 (5) |
| 2 | Red | 12 | Radio Power From Plug 5 Pin 2 | P |
| 3 | Purple | * 12 | CB 6 To Purple "ACC" In Power View Harness | P |
| 4 | Black | 20 | Ground | P |
| 5 | Brown | 503 | Road Light Switch | P |
| 6 | Red | 22 | CB 8 To Dome - Panel Switches - Radio Memory | P |
| *7 | Brown | 507 | Cab Field Lights Power | P |
| 8 | Brown | 572 | Work Light Switch To Left Work Light Relays | P |
| 9 | Purple | * 13 | Purple "Key" In Power View Harness To Power Solenoids In Panel | P |
| *10 | Brown | 526 | Cab Road Lights Power | White 58 |
| 11 | Blue | 652 | Fuel Gauge | 1 (5) |
| 12 | Red | * 11 | Red "POW" In Power View Harness To Plug 5 Pin 1 | P |
| 13 | Green | * 422 | Green "STRT" In Power View Harness To Stater Relay | P |
| 14 | Brown | 504 | Field Light Switch | P |
| *15 | Black | 156 | Auxillary Power Box | |
| 16 | | | | |

PLUG 5

PIN

COLUMN PLUG

| | | | | |
|----|------|--------|---|------------|
| 1 | 11 | Red | To Red "POW" In Power View Harness | 12 (3) |
| 2 | 12 | Red | Power From Key Switch "ACC" To Radio | 2 (3) |
| 3 | 13 | Red | Key Switch "IGN" To Ignition Terminal On Power Solenoids In Panel | P |
| 4 | 502 | Brown | Power From Turn Stat | 502 TO 507 |
| 5 | 104 | White | Clutch Switch N.C. To Start Relay | P |
| 7 | 112 | White | | |
| 9 | 507 | Brown | | |
| 10 | 512 | Brown | | |
| 11 | 11 | Green | | |
| 12 | 513 | Brown | | |
| 14 | 059 | Black | To Clutch Switch N.O. Position To 15 (5) | 15 (5) |
| 15 | 0015 | Red | XM Switch Pin 1 / Pin 3 "N.O. Red 15 To XA2 Module C1:39 | |
| 18 | 522 | Brown | Right Turn Signal - Brown 54 On Machine | 512 To 522 |
| 20 | 523 | Brown | Left Turn Signal - Yellow 53 On Machine | 513 To 523 |
| 24 | 924 | Orange | | |

4RSPH65LAH (7)

PLUG 4

SW#/PIN#

| 1 | Red | 21 | CB 7 To Cab Overhead | | |
|-------------|--------|----------------|---|---|------------|
| M111 Coding | | | | | |
| 1 | 2 | Green | Black | Blade Up Switch To Junction Panel | Red 118 |
| 1 | 3 | White / Green | Red | Blade Down Switch To Junction Panel | Black 119 |
| 2 | 4 | Yellow | Yellow | Boom Outer MV5 Valve Up | Orange 110 |
| 2 | 5 | White / Yellow | Brown | Boom Outer MV5 Valve Down | Blue 111 |
| 3 | 6 | Black | Violet | Boom Lift MV5 Valve Up | White 112 |
| 3 | 7 | White / Black | Gray | Boom Lift MV5 Valve Down | Brown 113 |
| 4 | 8 | Orange | Orange | Boom Swing MV5 Valve Up | Purple 114 |
| 4 | 9 | White / Orange | Blue | Boom Swing MV5 Valve Down | Green 115 |
| 5 | 10 | Brown | White/Brown | Left Blade Switch Up To junction Panel | Blue 30 |
| 5 | 11 | White / Brown | White/Black | Left Blade Switch Down To Junction Panel | Orange 35 |
| 6 | 12 | Gray | White/Red | Right Blade Switch Up To Junction Panel | Yellow 76 |
| 6 | 13 | White / Gray | White/Yellow | Right Blade Switch Down To Junction Panel | Brown 77 |
| 14 | Black | 51 | Airhead Discharge RDRS112-30 Actuator | | |
| 15 | Green | 605 | Airhead Fan RPM Pickup To XA2 Module To Cab | | |
| 16 | Orange | 52 | Airhead Discharge RDRS112-30 Actuator | | |
| 17 | Orange | 51 | Left Star Table Reverse | | |
| 18 | Blue | 57 | Right Star Table Reverse | | |
| 19 | Blue | 71 | Bin Fill Manual Switch To MD3 (Down) | | |
| 20 | Orange | 72 | Bin Fill Manual Switch To MD3 (Up) | | |
| 21 | Red | 75 | Bin Fill Automatic Switch To MD3 Panel Junction Block | | |
| 22 | Black | 108 | Rock Box MV5 Valve Up | | |
| 23 | Red | 109 | Rock Nbox MV5 Valve Down | | |
| 24 | Green | 78 | Bin Unload Switch to RDRS112-30 Actuator | | |
| 25 | Brown | 79 | Bin Unload Switch To RDRS112-30 Actuator | | |
| 26 | Orange | 47 | Boom RDRS112-30 Actuator | | |
| 27 | White | 48 | Boom RDRS112-30 Actuator | | |
| 28 | White | 41 | Travel Mode Switch To MD3 / XA2 Modules | | |
| 29 | White | 371 | Level Warning Light To MD3 / XA2 Modules | | |
| 30 | Blue | 93 | Star Table Distributors Reverse | | |
| 31 | Brown | 158 | Truck Lights Foot Switch "IN" X | | |
| 32 | Yellow | 159 | Truck Lights Foot Swiotch "OUT" X | | |
| 33 | Purple | 160 | Truck Lights Foor Switch "FORWARD" X | | |
| 34 | Orange | 161 | Truck Lights Foot Switch "BACK" X | | |
| 35 | White | 11 | Primary Load Cells Enable Signal To XA2 (2) | | |
| 36 | | | M115 Trigger Switch - Not Used | | |
| 37 | Green | 091 | CB 2 To M115 Joystick Handle | | |

Violet (Green)

Red (White)

4RSPH65LAH (7)

PLUG 5

COLUMN PLUG

| PIN # | | | | |
|-------|------|--------|---|------------|
| 1 | 11 | Red | To Red "POW" In Power View Harness | 12 (3) |
| 2 | 12 | Red | Power From Key Switch "ACC" To Radio | 2 (3) |
| 3 | 13 | Red | Key Switch "IGN" To Ignition Terminal On Power Solenoids In Panel | P |
| 4 | 502 | Brown | Power From Turn Stat | 502 TO 507 |
| 5 | 104 | White | Clutch Switch N.C. To Start Relay | P |
| 7 | 112 | White | | |
| 9 | 507 | Brown | | |
| 10 | 512 | Brown | | |
| 11 | 11 | Green | | |
| 12 | 513 | Brown | | |
| 14 | 059 | Black | To Clutch Switch N.O. Position To 15 (5) | 15 (5) |
| 15 | 0015 | Red | XM Switch Pin 1 / Pin 3 "N.O. Red 15 To XA2 Module C1:39 | |
| 18 | 522 | Brown | Right Turn Signal - Brown 54 On Machine | 512 To 522 |
| 20 | 523 | Brown | Left Turn Signal - Yellow 53 On Machine | 513 To 523 |
| 24 | 924 | Orange | | |

PLUG #6

Belden 8619

| | | | |
|----|----------------|--|----------------|
| 1 | Black | Airhead Controller Power Supply Junction 4 | 8619 |
| 2 | Blue | Airhead Potentiometer Pin 2 Command Signal Junction 2 | 8619 |
| 3 | Orange | Airhead Potentiometer Pin 3 Command Signal Junction 3 | 8619 |
| 4 | White | Airhead Potentiometer Pin 1 Command Signal Junction 21 | 8619 |
| 5 | Black / White | Left / Right Primary Power Supply Junction 55 XA2 (2) | 8619 / XA2 (2) |
| 6 | Red | Left Primary Potentiometer Pin 1 Command Signal Junction 71 XA2 (2) | 8619 / XA2 (2) |
| 7 | Blue / White | Left Primary Potentiometer Pin 2 Command Signal Junction 57 XA2 (2) | 8619 / XA2 (2) |
| 8 | Green / White | Left Primary Potentiometer Pin 3 Command Signal Junction 76 XA2 (2) | 8619 / XA2 (2) |
| 9 | Red / White | Right Primary Potentiometer Pin 1 Command Signal Junction 71 XA2 (2) | 8619 / XA2 (2) |
| 10 | Blue / Black | Right Primary Potentiometer Pin 2 Command Signal Junction 58 XA2 (2) | 8619 / XA2 (2) |
| 11 | Red / Black | Right Primary Potentiometer Pin 3 Command Signal Junction 76 XA2 (2) | 8619 / XA2 (2) |
| 12 | Green / Black | Secondary Controller Power Supply Junction 16 | 8619 |
| 13 | Orange / Black | Secondary Potentiometer Pin 1 Command Signal Junction 24 | 8619 |
| 14 | Green | Secondary Potentiometer Pin 2 Command Signal Junction 14 | 8619 |
| 15 | White / Black | Secondary Potentiometer Pin 3 Command Signal Junction 15 | 8619 |
| 16 | Black / Red | Trash Fan Controller Power Supply Junction 20 | 8619 |
| 17 | White / Red | Trash Fan Potentiometer Pin 1 Command Signal Junction 25 | 8619 |
| 18 | Orange / Red | Trash Fan Potentiometer Pin 2 Command Signal Junction 18 | 8619 |
| 19 | Blue / Red | Trash Fan Potentiometer Pin 3 Command Signal Junction 19 | 8619 |
| 20 | | | |
| 21 | | | |
| 22 | | | |
| 23 | | | |
| 24 | | | |

4RSPH65LAH (7)

LARGE 16 PIN PLUG

PLUG #7

| | | | | | |
|-----|----------------|----------|--|----------------|-------|
| *1 | Orange | 90 (H) | Main Power Reset Relay (N.O.) To Master Switch | | |
| 2 | Brown | 115 | M115 "A" Forward To Relays | | |
| 3 | Purple | 115 | M115 "B" Reverse To Relays | | |
| 4 | Black (8770) | #5 | M115 Signal To MD3 / XA2 Modules | Belden 8770 #5 | Black |
| 5 | Red (8770) | #5 | M115 +VBATT To MD3 / XA2 Modules | Belden 8770 #5 | Red |
| 6 | Clear (8770) | #5 | M115 Ground To MD3 / XA2 Modules | Belden 8770 #5 | Clear |
| *7 | Yellow | 89 (H) | Main Power Reset Relay (N.O.) To Master Switch | | |
| 8 | | | | | |
| 9 | | | | | |
| *10 | Black | 0012 (H) | CB 7 To Hi / Lo Switch | | |
| 11 | Red | 0028 | Camera System Power | | |
| 12 | Black | 0015 | Camera System Ground | | |
| 13 | | | | | |
| 14 | Black | 95 | Airhead Deflector Switch To MV5 Valve | | |
| *15 | | | | | |
| 16 | White | 96 | Airhead Deflector Switch To MV5 Valve | | |

PLUG 8

PIN

| | | | | | |
|----|-----------|-----|--|-------|-----|
| 1 | Gray | 1 | -BAT | C1:1 | MD3 |
| 2 | Gray | 2 | CAN-A L | C1:2 | MD3 |
| 3 | Gray | 3 | CAN-B-L | C1:3 | MD3 |
| 4 | Gray | 7 | +RTC | C1:7 | MD3 |
| 5 | Gray | 10 | CAN-B-H | C1:10 | MD3 |
| 6 | Gray | 11 | CAN-A H | C1:11 | MD3 |
| 7 | Gray | 12 | +BAT | C1:12 | MD3 |
| 8 | Black | 1 | VIN-A | C2:1 | MD3 |
| 9 | Black | 2 | VIN-B | C2:2 | MD3 |
| 10 | Black | 3 | VIN-C | C2:3 | MD3 |
| 11 | Black | 4 | DIN- D | C2:4 | MD3 |
| 12 | Black | 5 | -VREF | C2:5 | MD3 |
| 13 | Black | 6 | USB- D- | C2:6 | MD3 |
| 14 | Black | 7 | USB- D+ | C2:7 | MD3 |
| 15 | Black | 8 | +VREF | C2:8 | MD3 |
| 16 | Black | 9 | DIN- E | C2:9 | MD3 |
| 17 | Black | 10 | DIN- F | C2:10 | MD3 |
| 18 | Black | 11 | DIN- G | C2:11 | MD3 |
| 19 | Red | 230 | Auxillary Fuse #7 To Greentronics Monitor - power | | |
| 20 | Black | 230 | Auxillary Fuse Panel Ground To Greentronics Monitor - Ground | | |
| 21 | Black | 229 | Interface Controller Pin A To Monitor | | |
| 22 | White | 229 | Interface Controller Pin B To Monitor | | |
| 23 | Red | 229 | Interface Controller Pin +12V To Monitor | | |
| 24 | Bare Wire | 229 | Interface Controller Pin GND To Monitor | | |

A. H. FAN



FILTER WARN



GROUND DRIVE



LOW
HYDRAULIC
OIL

H. RANGE



LO RANGE

GROUND
DRIVE

4X4



4X2



FUEL PUMP

BACKUP



LIGHTS



FLASHERS

PARKING
BRAKE



OFF



STROBE
LIGHT



REAR
LIGHT

FLASHERS

FUSE PUMP

Hydro Remote

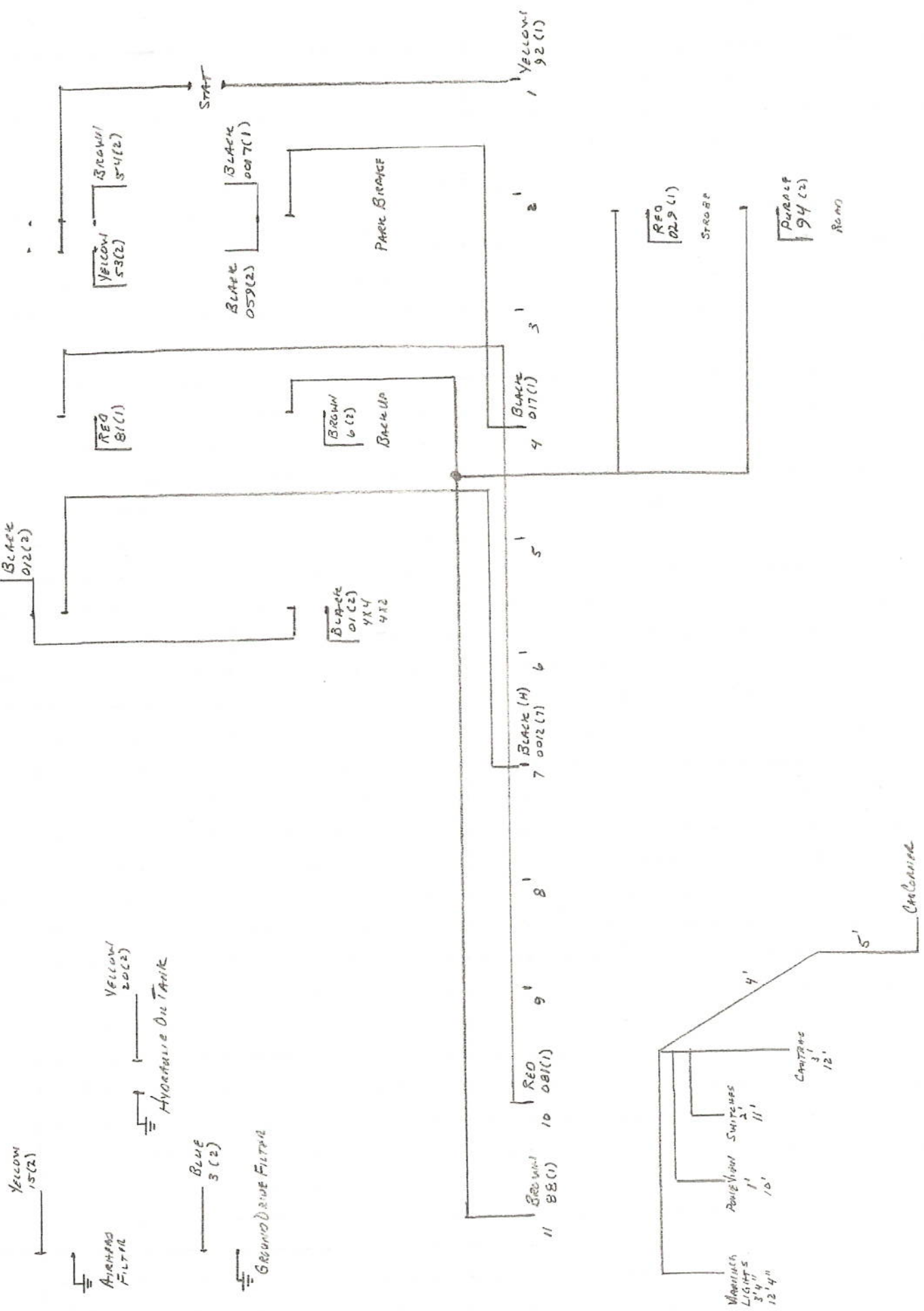

FOOT PLATE SWITCHES

CENTERING

SECONDARY

STEERING

REVERSING

LEFT

RIGHT

LEFT
PRIMARY

RIGHT
PRIMARY

CENTERING

(STEERING COLUMN)

FOOT PLATE SWITCHES

CENTERING
○

STEERING

LEFT RIGHT



○ SECONDARY

REVERSING

LEFT PRIM RIGHT PRIM

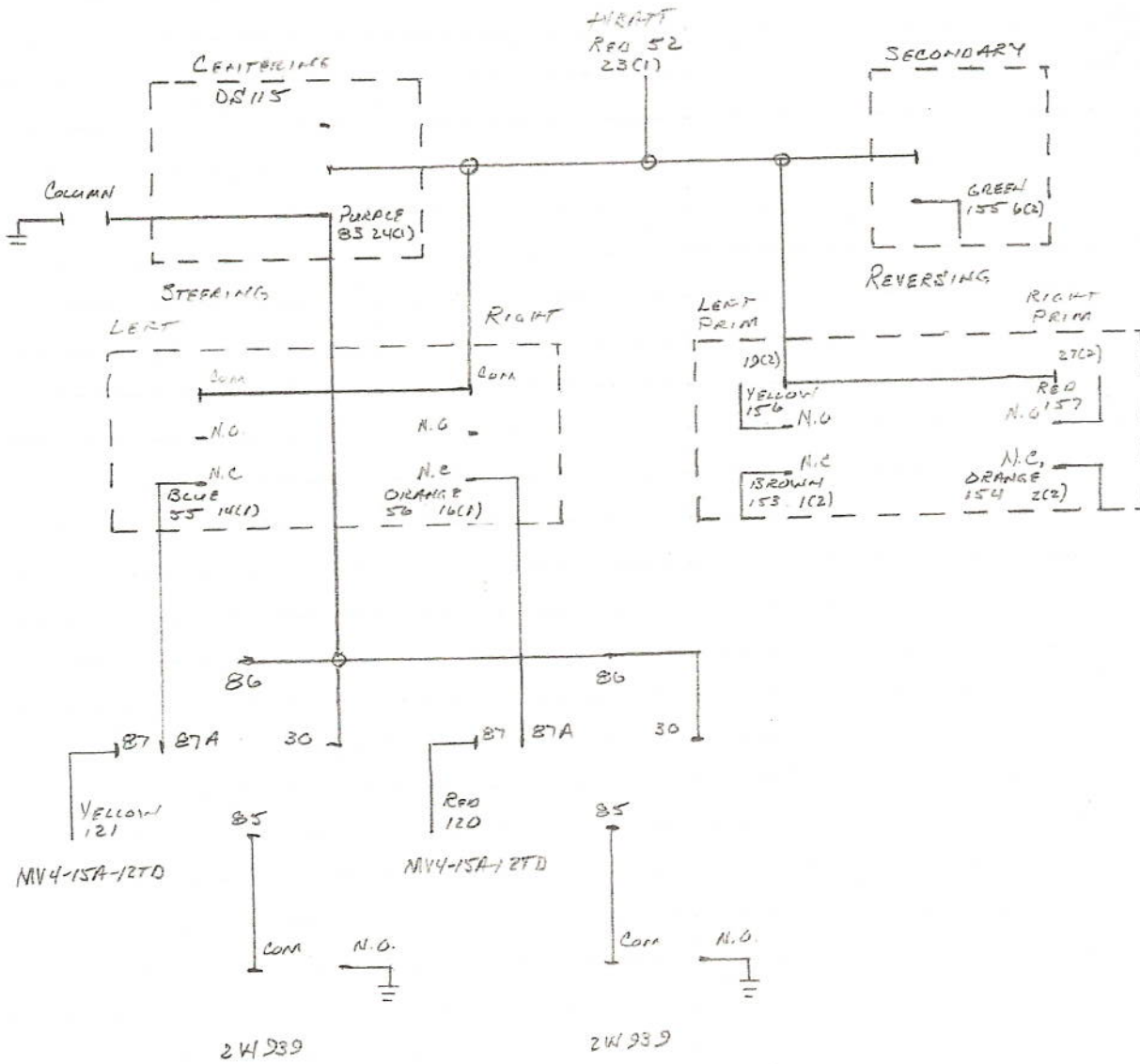

AIR HEAD CLEANING

CLEANER VALVE
 02-135316 (2017-04000)
 BASE
 CD03-6T (2017-04601)

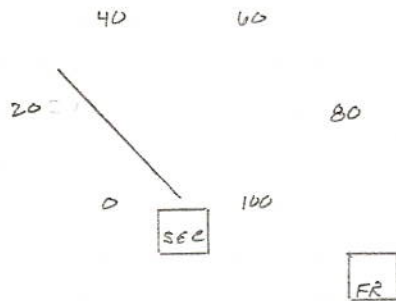
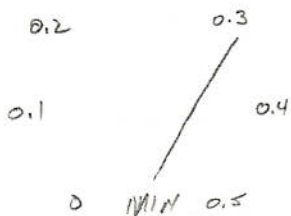
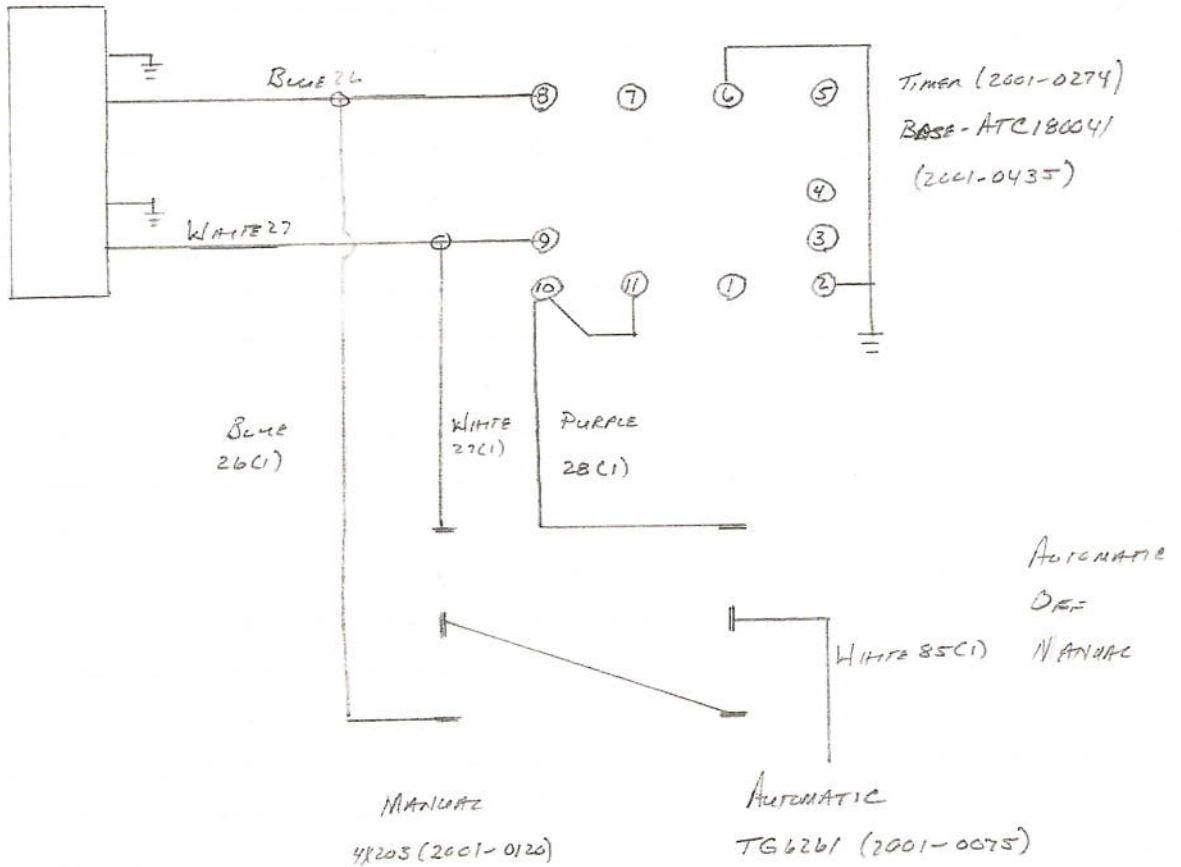

4/26/16
 216081
 INTEGRITY AG.
 4RSDH65LHA (1)

B I H F I L L L STARTABLE REVERSE AIRHEAD CLEANER
 ON AUTOMATIC

SYSTEM ERROR TRAIL MANUAL MODE MANUAL OFF LEFT RIGHT DISTILLS. MANUAL MANUAL RESET
 AIRHEAD PRIMARY AIRHEAD SECONDARY L N T R O L S
 AIRHEAD PUMP BOOM STEEL ROLLS
 OFF LEFT RIGHT FEED DISCHARGE FULL UNLOAD SPACE

C O N V E E Y O R S TRASH FAN STAR TABLE

MASTER PRIMARY MASTER SECONDARY CROSS AIRHEAD BIN BOOM OFF SPEED LEFT RIGHT DISCHARGE ROLLS
 FEED DISCHARGE

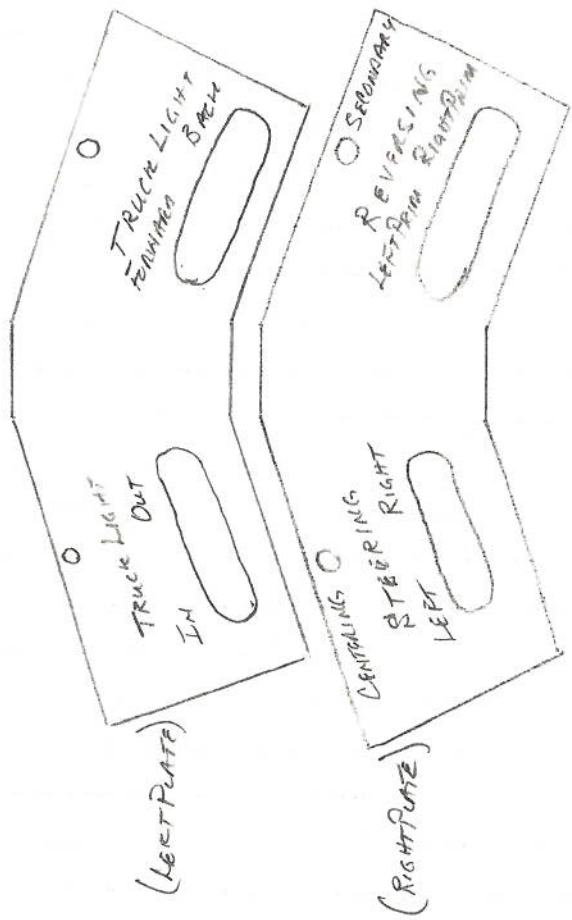

SHAKER RAISE LOWER
 ROCK RAISE LOWER
 STRIPPER LOWER LOWER
 COUETTE LOWER LOWER
 HUMPSHAFT

BLADE MASTER BOOM OUTER LIFT BOOM BOOM SWING
 SLADE LEFT SLADE RIGHT

4/29/16
 #16081
 INTEGRITY
 MRSPH5A.H(C)

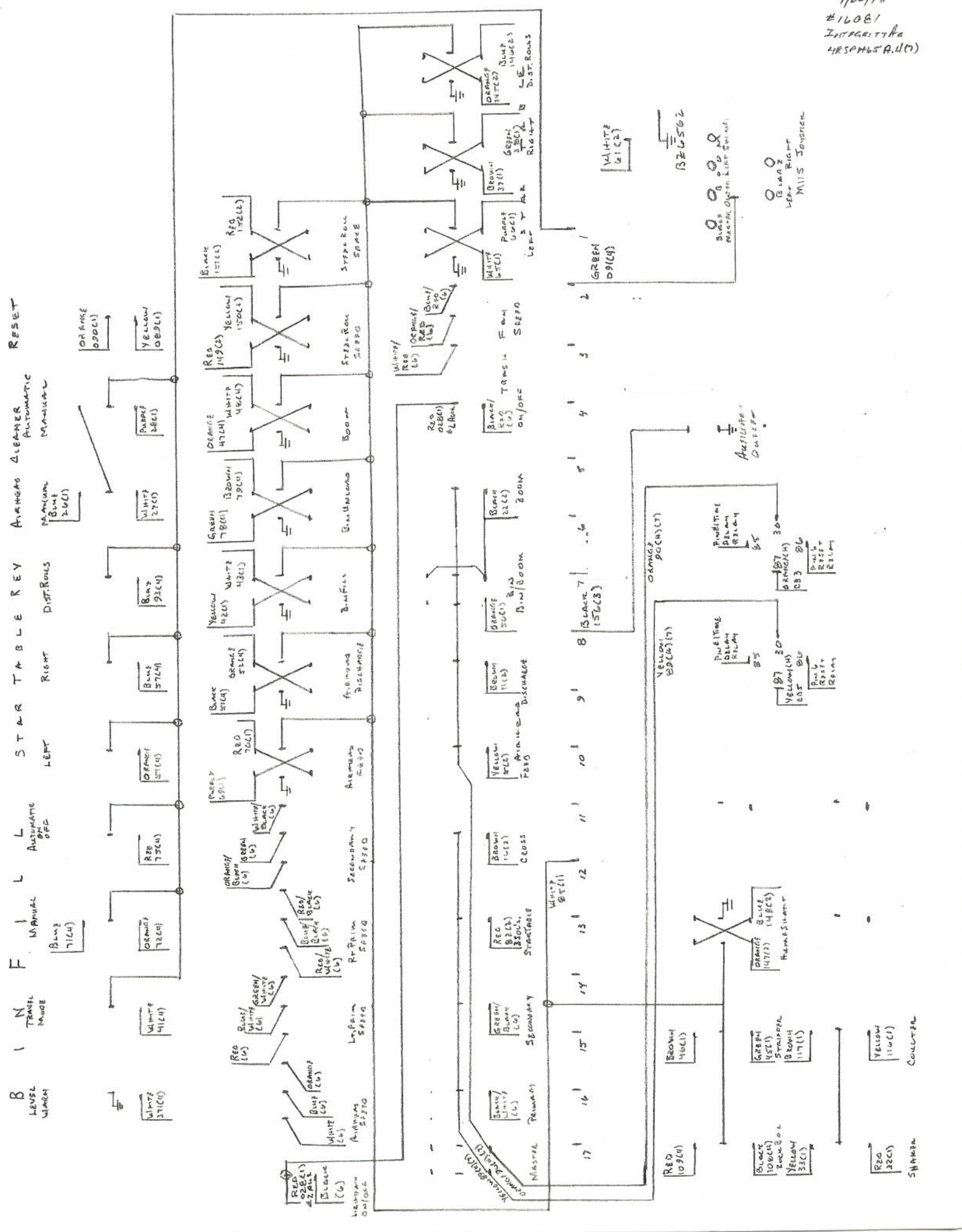

3/14/16
 #16081
 INTEGRITY A6
 HP-PULSAR (1)

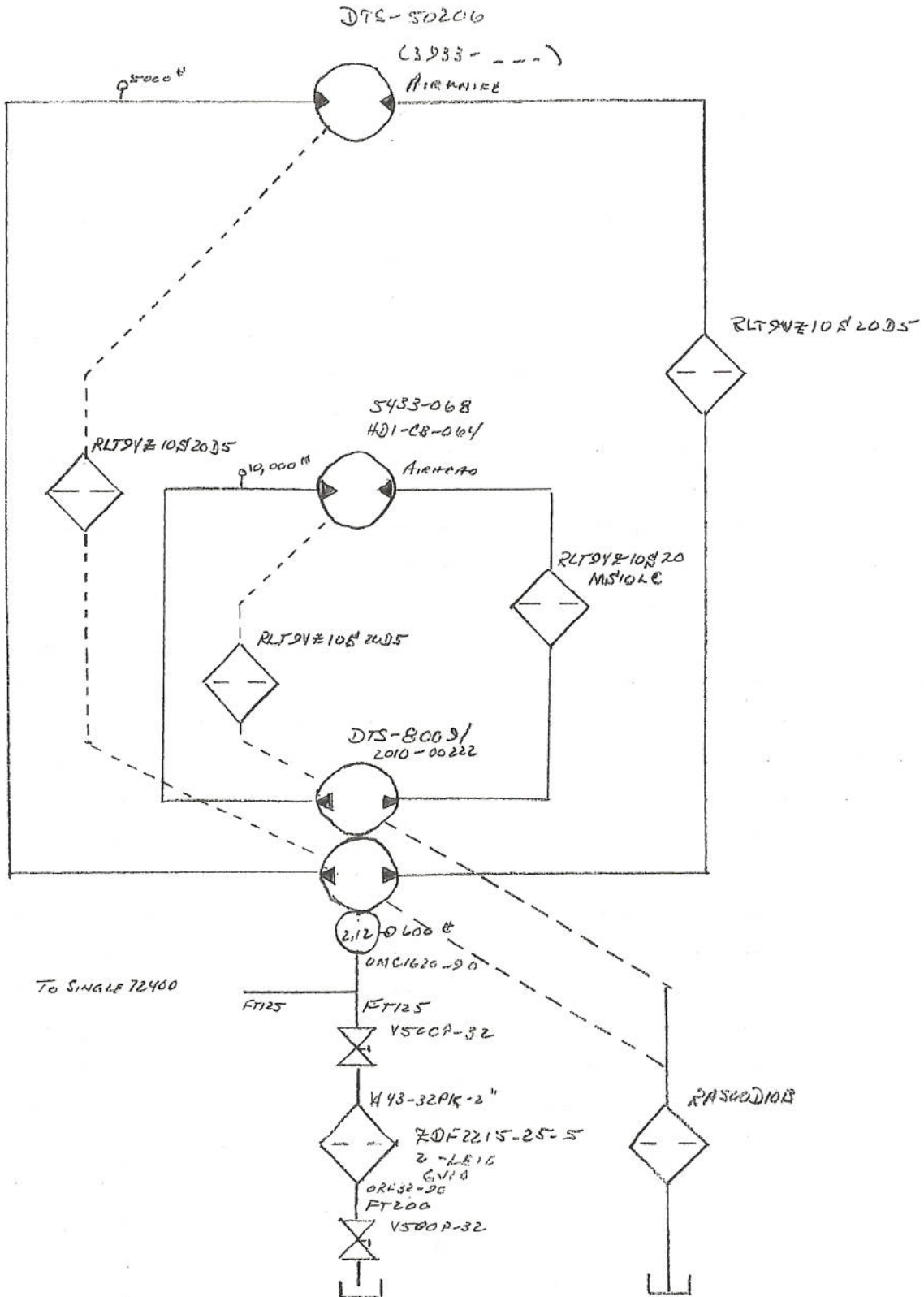

9/21/16
E16081

INTEGRITY AG.
4RSPH6SLAH
DRAINAGE PUMP REVISION!

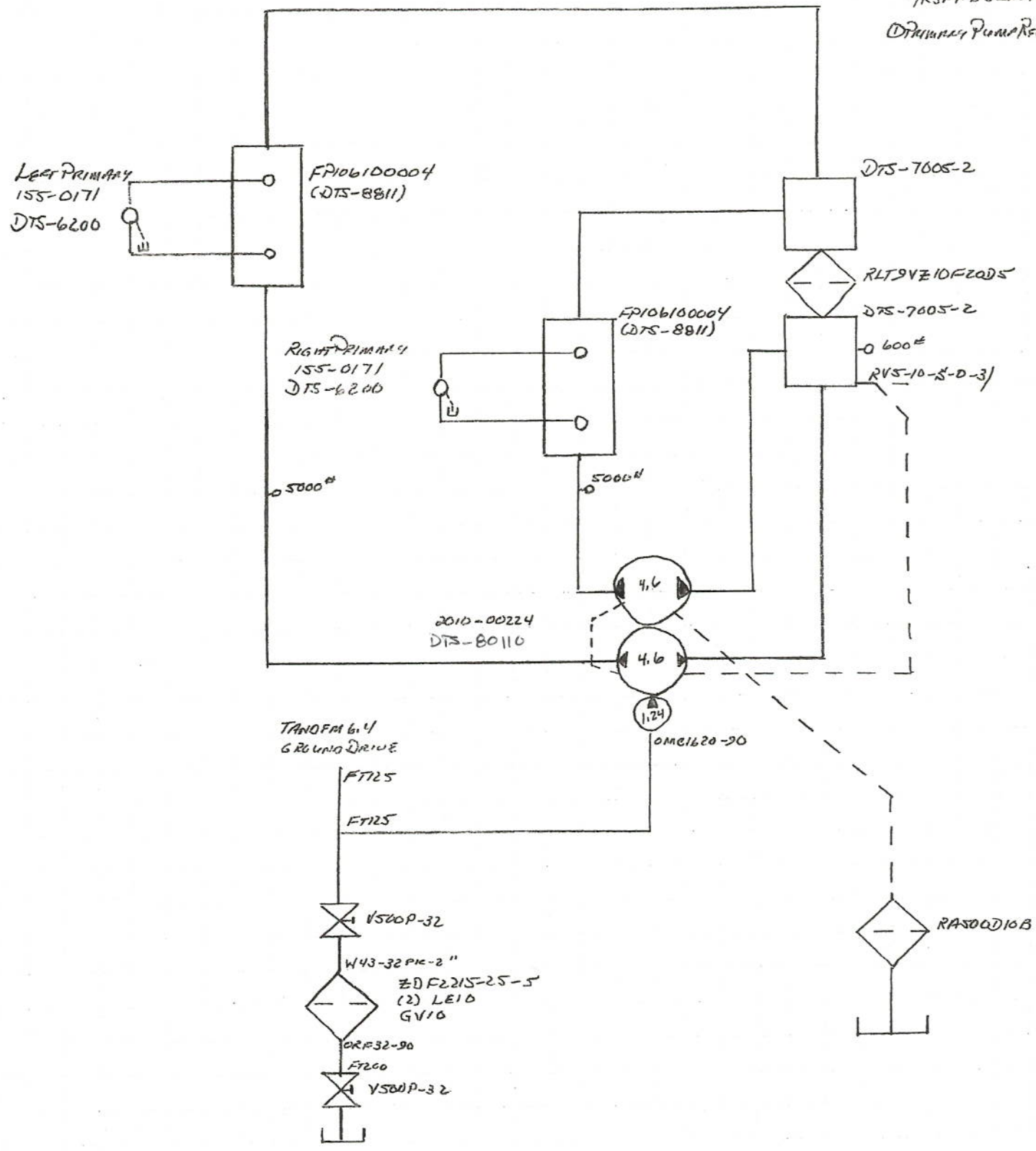

3/14/16 E16081
 INTEGRITY AG
 4056465241177

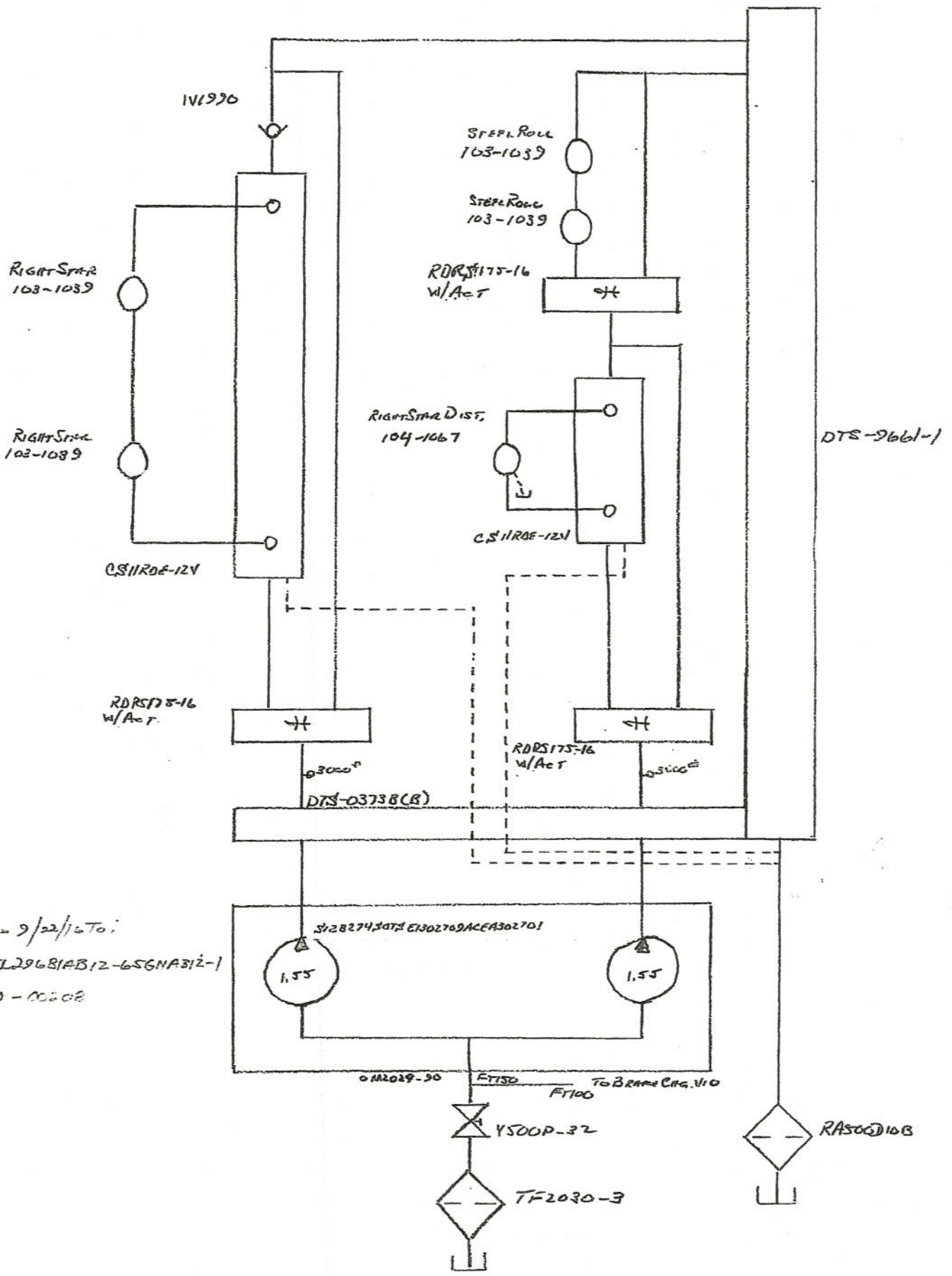

CHANGED 9/22/16 TO:
 P031SL29681AB12-656NA312-1
 2010-00008

0M2029-90 E1750 F1100 To Brake CAG. V10

3/15/16
 #16081
 INTEGRITY A
 4RSP4652A(1)

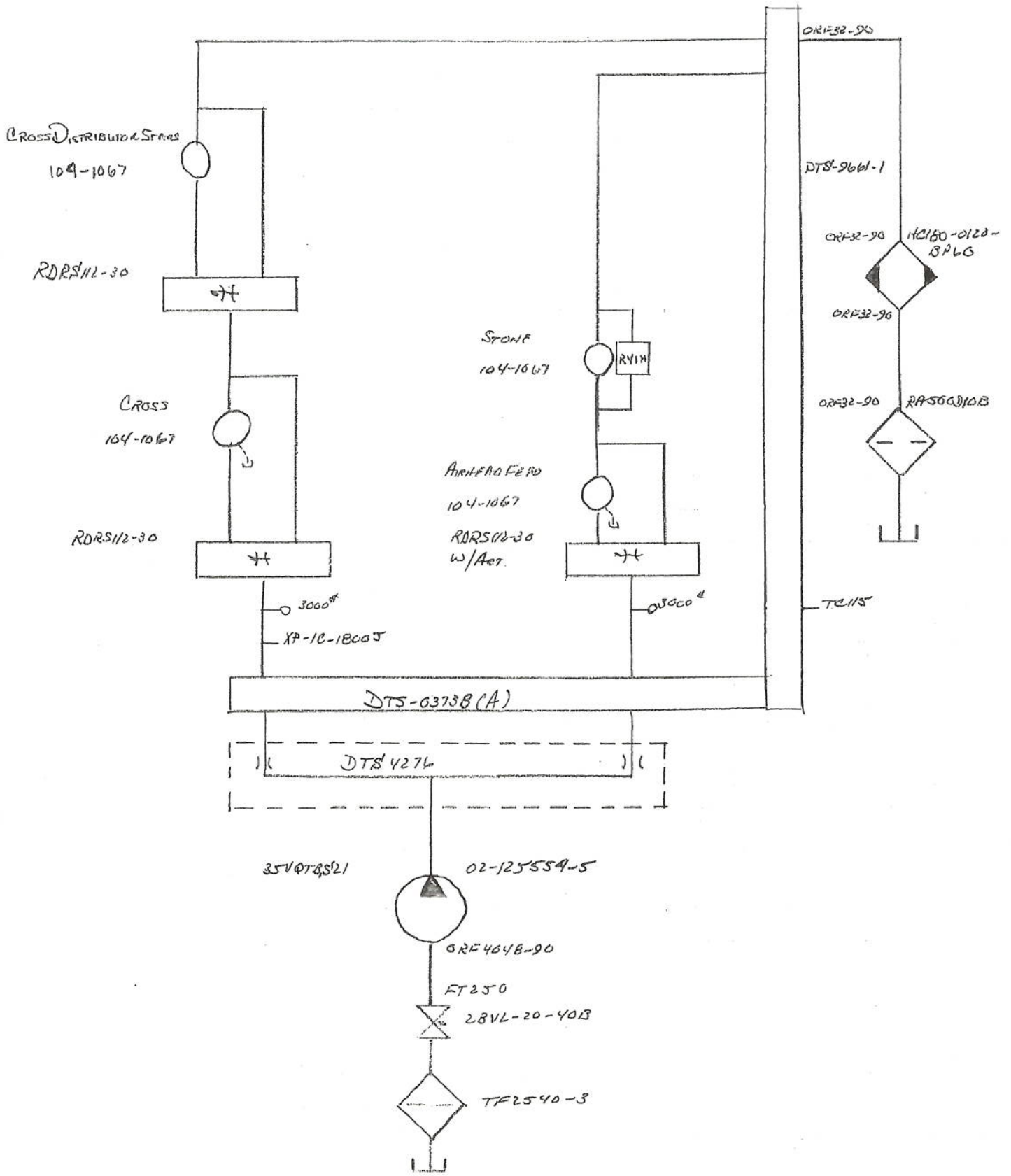

5/13/16 E16081
 INTEGRITY AG
 HRS#H65L4H (7)

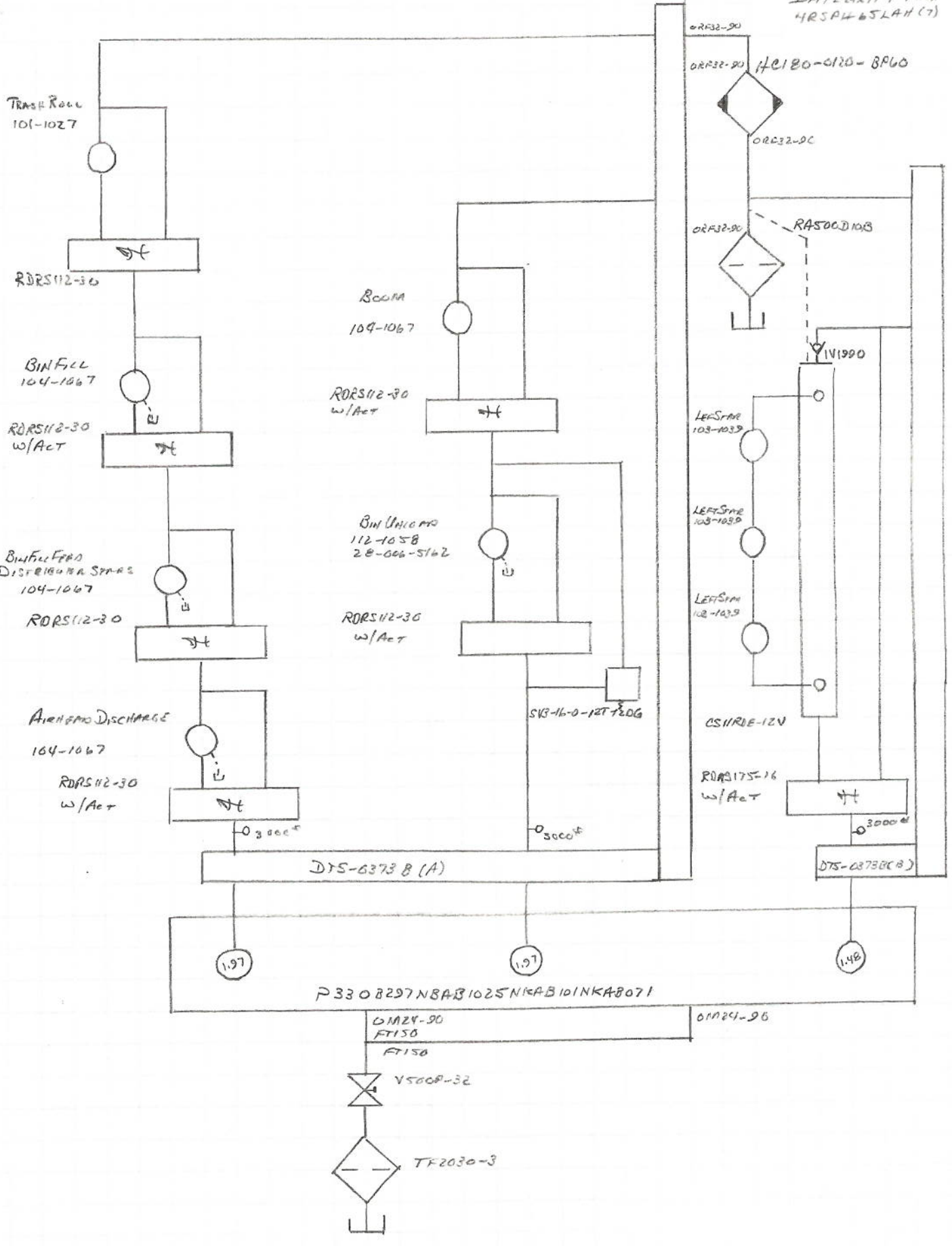

3/15/16
 #16081
 INTEGRITY AG
 YES P&ID (7)

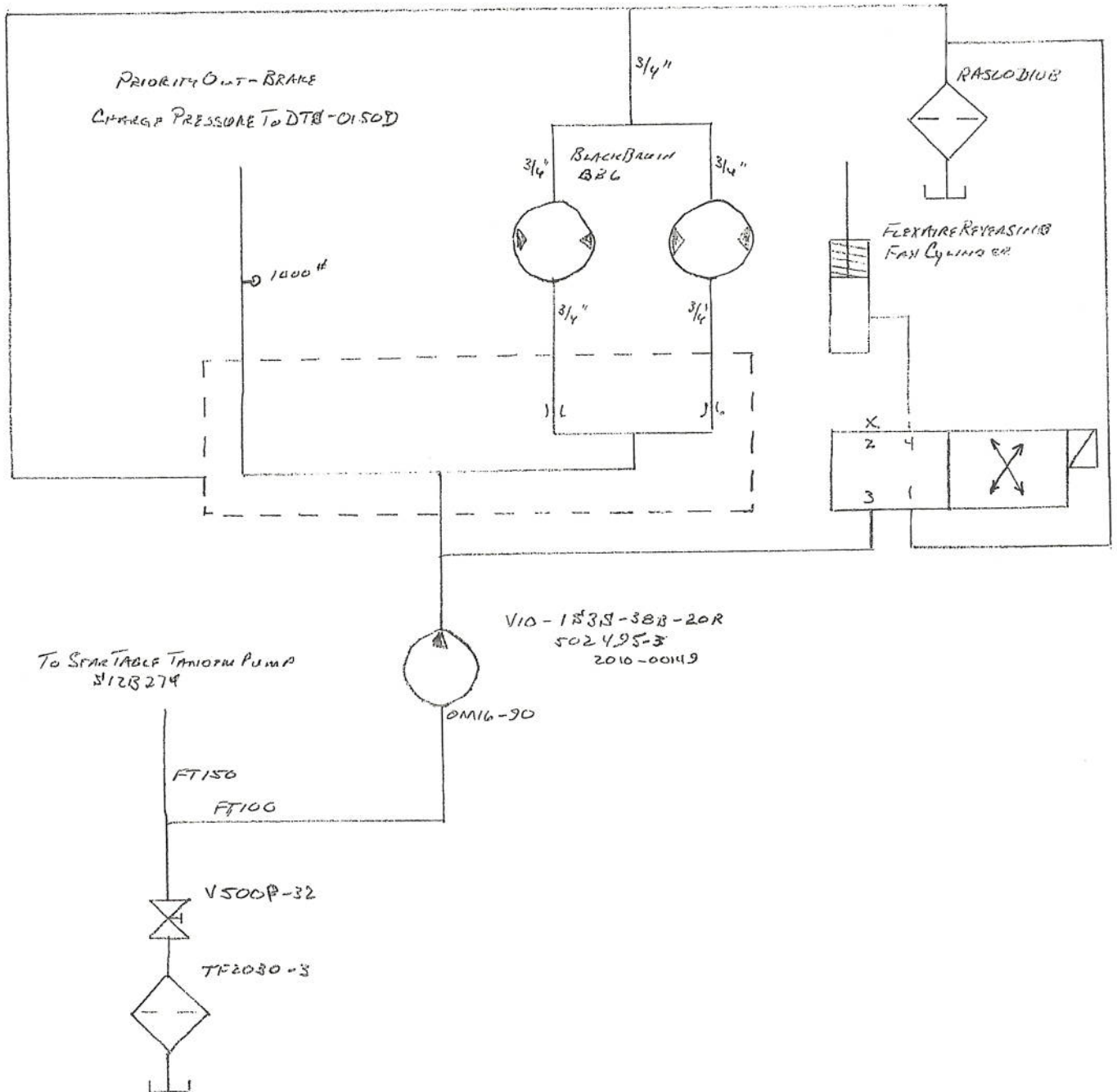

6/1/16 16081
 INTEGRITY AG
 11250462 (AH 07)

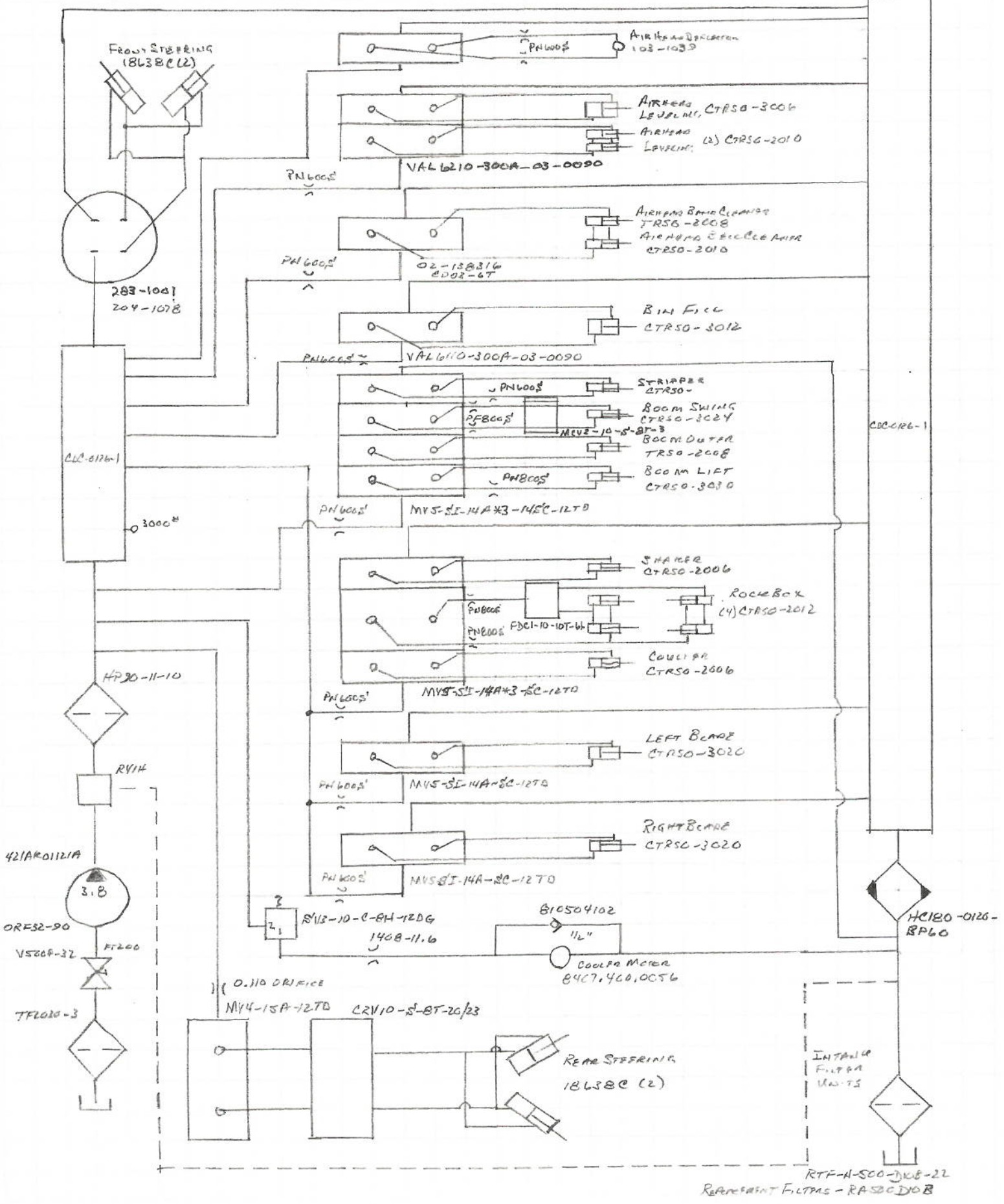

RTF-A-500-216-22
 REFRIGERANT FILTERS - RA500D08

3/16/10 #16081
 INTERRIT AG
 YRSN+SCANN (7)

④
 TF2540-3
 2 1/2" 90° S.F.E.C.
 2 1/2" C.S.N.I.P.
 2 B.V.L. 20.20/20.20
 FT250
 * 354QTBS'

③
 3" X 2" Bush
 2" C.S.N.I.P.
 V500P-32
 FT200
 ORF32-90
 ZOF2215-25-5
 W43-32PK-2"
 2" 90° S.F.E.C.
 2" C.S.N.I.P.
 V500P-32
 2" C.S.N.I.P.
 2" TEE
 X 2" X 1 1/4" Bush
 O 2" 90° S.F.E.C.
 FT125
 Ground Wire
 * Tan. 6.4/6.4
 * Tan. 3.0/3.0

③
 TF2030-3
 2" C.S.N.I.P.
 V500P-32
 2" 90° S.F.E.C.
 FT200
 * 421AIC

③
 TF2030-3
 2" 90° S.F.E.C.
 2" C.S.N.I.P.
 V500P-32
 2" C.S.N.I.P.
 2" TEE
 X 2" X 1 1/2" Bush
 FT150
 * P.330
 O 2" 90° S.F.E.C.
 2" X 1 1/2" Bush
 FT150
 * P.330

③
 TF2030-3
 2" 90° S.F.E.C.
 2" C.S.N.I.P.
 2" TEE
 X 2" X 1 1/2" Bush
 FT150
 V.P.C. 20.20/20.20
 O 2" 90° S.F.E.C.
 2" X 1" Bush
 FT100
 * V10

④
 4" X 2" Bush
 2" C.S.N.I.P.
 V500P-32
 FT200
 ORF32-90
 ZOF2215-25-5
 W43-32PK-2"
 2" 90° S.F.E.C.
 2" C.S.N.I.P.
 V500P-32
 2" C.S.N.I.P.
 2" TEE
 X 2" X 1 1/4" Bush
 O 2" X 1 1/4" Bush
 1 1/4" 45° S.F.E.C.
 FT125
 * Tan. 6.4/6.4
 * Tan. 3.0/3.0
 * 72400
 Airt-BAG/Arkenite

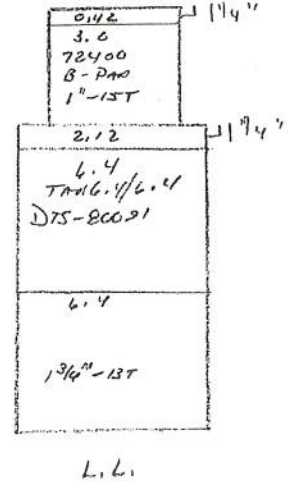
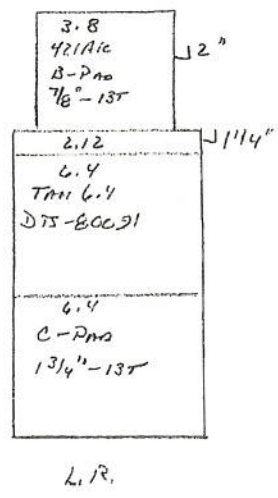
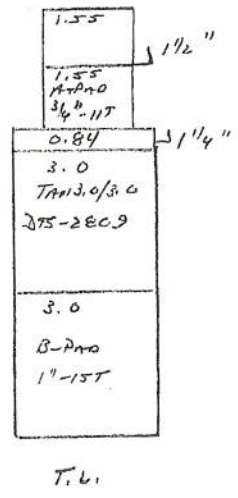
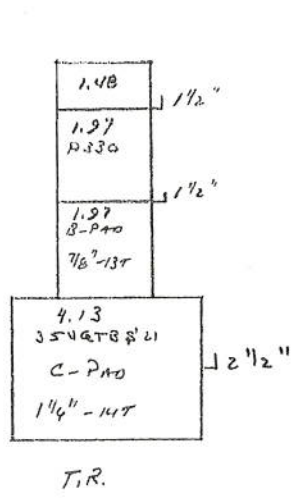

DURST 4PD11-116I-N11-88B4-CL4-CE4-CE4-L8
 TORSION CONTROL - Z-19347

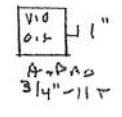

3/16/16
#16081
INTEGRITY AG.
4RSPH6TEAM (7)

846

886

AVENUE FLOOR
104-1067

AVENUE FLOOR
5433-068
HDI-CB-072

DISTRIBUTION
STAIR
104-1067

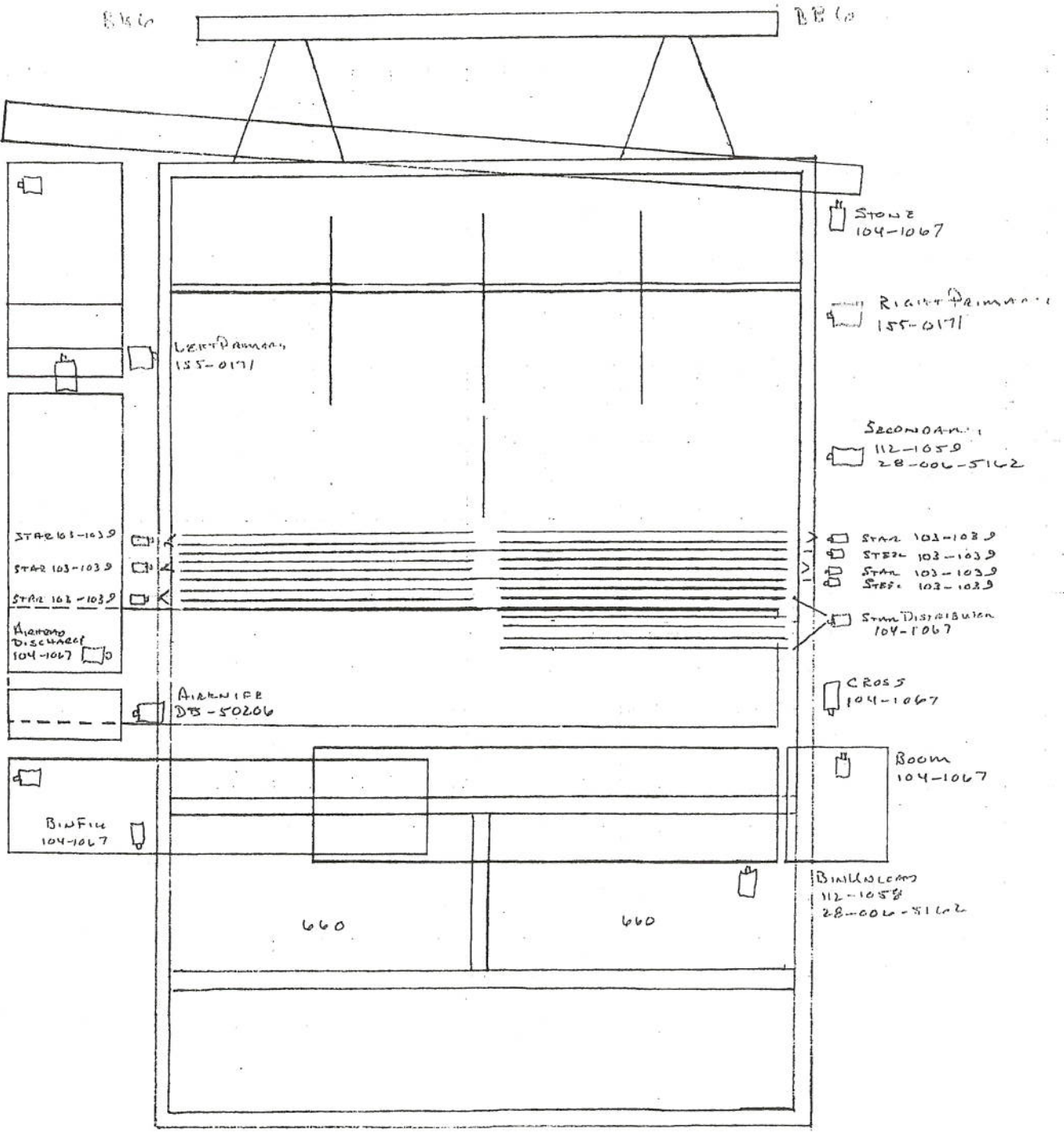

STAR 103-1039
STAR 103-1039
STAR 103-1039
AVENUE DISCHARGE
104-1067

LEFT PANELS
155-0171

AVENUE
DB-50206

STAR
104-1067

RIGHT PANELS
155-0171

SECONDARY
112-1058
28-006-5162

STAR 103-1039
STAR 103-1039
STAR 103-1039
STAR 103-1039

STAR DISTRIBUTION
104-1067

CROSS
104-1067

Room
104-1067

BIN ROOM
112-1058
28-006-5162

660

660

16081

Integrity Ag.

5/1/2016

4RSPH65LAH (7)

KAR-TECH ENCLOSURE

PLUG #1

| PIN # | | | Belden 8619 |
|-------|---------------|--|-------------|
| 1 | Blue | Airhead Potentiometer Pin 2 Command Signal Junction 2 | 8619 |
| 2 | Orange | Airhead Potentiometer Pin 3 Command Signal Junction 3 | 8619 |
| 3 | Black | Airhead Controller Power Supply Junction 4 | 8619 |
| 4 | | | |
| 5 | | | |
| 6 | | | |
| 7 | | | |
| 8 | | | |
| 9 | Green | Secondary Potentiometer Pin 2 Command Signal Junction 14 | 8619 |
| 10 | White / Black | Secondary Potentiometer Pin 3 Command Signal Junction 15 | 8619 |
| 11 | Green / Black | Secondary Controller Power Supply Junction 16 | 8619 |
| 12 | Black | 0020 Kar-Tech Ground Junction 26 To Panel | P |

PLUG #2

| PIN # | | | Belden 8619 |
|-------|----------------|---|-------------|
| 1 | | | |
| 2 | | | |
| 3 | White | Airhead Potentiometer Pin 1 To Junction 21 | 8619 |
| 4 | Orange / Black | Secondary Potentiometer Pin 1 To Junction 24 | 8619 |
| 5 | Black / Red | Trash Fan Controller Power Supply Junction 20 | 8619 |
| 6 | White / Red | Airknife Potentiometer Pin 1 Command Signal Junction 25 | 8619 |
| 7 | Orange / Red | Airknife Potentiometer Pin 2 Command Signal Junction 18 | 8619 |
| 8 | Blue / Red | Airknife Potentiometer Pin 3 Command Signal Junction 19 | |
| 9 | | | |
| 10 | | | |
| 11 | | | |
| 12 | | | |

PLUG #3

| PIN # | | | Belden 8468 |
|-------|---------------|--|-------------|
| 1 | Red | Airhead Junction 1 To Coil #1 - Pin "A" | 8468 |
| 2 | | | |
| 3 | | | |
| 4 | White | Secondary Junction 13 To Coil #1 - Pin "A" | 8468 |
| 5 | | | |
| 6 | | | |
| 7 | Red / Black | Airhead Coil #1 - Pin "B" - Junction 21 | 8468 |
| 8 | White / Black | Secondary Coil #1 - Pin "B" - Junction 24 | 8468 |
| 9 | Blue | Airknife Junction 17 To Coil #1 - Pin "A" | 8468 |
| 10 | Orange | Airknife Coil #1 - Pin "B" - Junction 25 | 8468 |
| 11 | | | |
| 12 | | | |

| | |
|---------------|---|
| LEFT PRIMARY | 1 |
| RIGHT PRIMARY | 2 |
| AIR HEAD | 3 |
| SECONDARY | 4 |
| TRASH FAN | 5 |

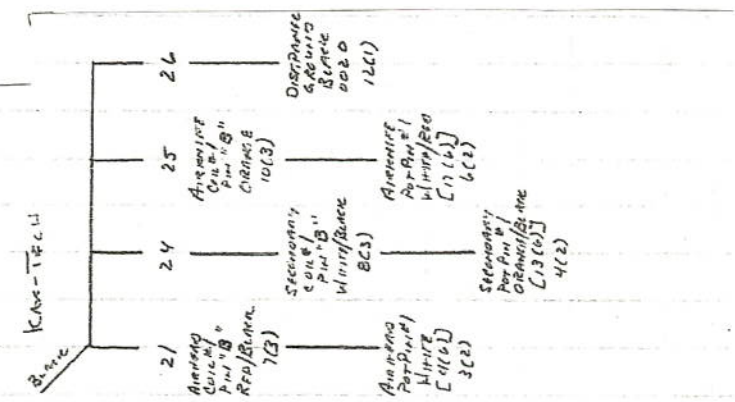
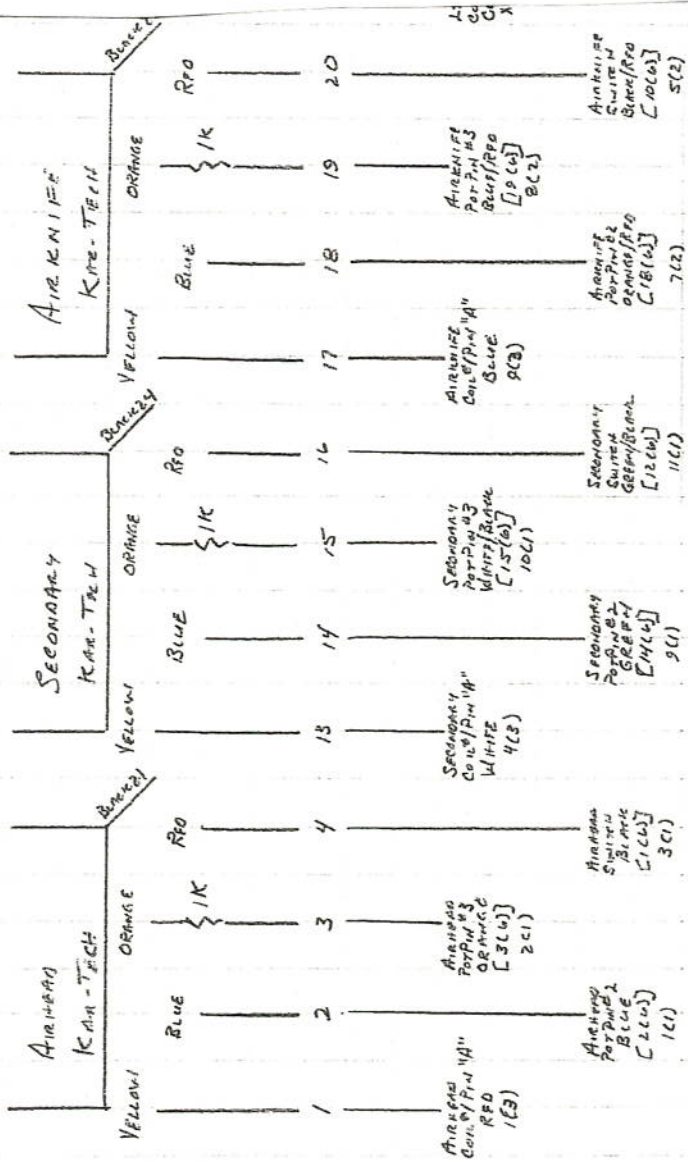

4RSPH65LAH (7)
BIN / AIR HEAD ELECTRONIC LEVELING

Pink *Black* *Wire Num B-R* *Pin* *Terminal*

| PLUG 1 | | | | | | |
|--------|--------|----------|--------------------------------|-------|---------|----|
| 1 | Blue | 1 | Bin Level Sensor 1 Gound | C1:1 | MD3 | 1 |
| 2 | Brown | 1 | Bin Level Sensor 1 12Vdc | C2:4 | MD3 | 12 |
| 3 | White | 1 | Bin Level Sensor 1 Signal | C1:10 | XA2 (1) | 25 |
| 4 | Black | 6 | Bin Level Control Coil 1 Pin A | C1:4 | XA2 (1) | 21 |
| 5 | Red | 6 | Bin Level Control Coil 1 Pin B | C1:18 | XA2 (1) | 34 |
| 6 | White | 6 | Bin Level Control Coil 2 Pin A | C1:4 | XA2 (1) | 21 |
| 7 | Green | 6 | Bin Level Control Coil 2 Pin B | C1:32 | XA2 (1) | 46 |
| 8 | Red | 280 (P) | Real Time Clock | C1:7 | MD3 | 4 |
| 9 | Black | 15 (P) | -BAT | C1:15 | XA2 (1) | 28 |
| 10 | Red | 28 (P) | +BAT | C1:28 | XA2 | 41 |
| 11 | Brown | 1115 (P) | Panel Junction Block | C1:30 | XA2 | 44 |
| 12 | Purple | 1115 (P) | Panel Junction Block | C1:31 | XA2 44 | 45 |

| PLUG 2 | | | | | | |
|--------|-------|----|--|-------|---------|----|
| 1 | Red | 8 | Speed Sensor +BAT Pin 1 (Brown) | C1:28 | XA2 (1) | 43 |
| 2 | Black | 8 | Speed Sensor S2 Pin 2 (Black) | C1:38 | XA2 (1) | 48 |
| 3 | Green | 8 | Speed Sensor GND Pin 4 (Blue) | C1:15 | XA2 (1) | 30 |
| 4 | Clear | 8 | Speed Sensor GND Pin 5 (Transparent) | C1:15 | XA2 (1) | 31 |
| 5 | Black | 9 | Motor Displacement Control Pin 1 | C1:19 | XA2 (1) | 35 |
| 6 | Clear | 9 | Motor Displacement Control Pin 2 | C1:5 | XA2 (1) | 22 |
| 7 | Black | 11 | Motor Control Pressure Transducer Signal Pin 1 | C2:1 | MD3 | 8 |
| 8 | Red | 11 | Motor Control Pressure Transducer +VREF Pin 2 | C 2:8 | MD3 | 17 |
| 9 | White | 11 | Motor Control Pressure Transducer -VREF Pin 3 | C2:5 | MD3 | 14 |
| 10 | Blue | 2 | Bin Level Sensor 2 Ground | C1:1 | MD3 | 1 |
| 11 | Brown | 2 | Bin Level Sensor 2 12Vdc | C2:4 | MD3 | 12 |
| 12 | White | 2 | Bin Level Sensor 2 Signal | C1:11 | XA2 | 26 |

| PLUG 3 | | | | | | |
|--------|-------|----|--------------------------------|---------|-------|------------|
| 1 | Green | 3 | Ground Drive Pump Coil 2 Pin C | Forward | C1:6 | XA2 (1) 23 |
| 2 | Red | 3 | Ground Drive Pump Coil 2 Pin D | Forward | C1:20 | XA2 (1) 36 |
| 3 | Black | 3 | Ground Drive Pump Coil 1 Pin A | Reverse | C1:6 | XA2 (1) 23 |
| 4 | White | 3 | Ground Drive Pump Coil 1 Pin B | Reverse | C1:34 | XA2 (1) 47 |
| 5 | | | | | | |
| 6 | | | | | | |
| 7 | | | | | | |
| 8 | | | | | | |
| 9 | Red | 12 | Airhead Inclinomter Pin1 | | C1:28 | XA2 (2) 69 |
| 10 | Black | 12 | Airhead Inclinomter Pin 2 | | C1:15 | XA2 (2) 60 |
| 11 | White | 12 | Airhead Inclinomter Pin 3 | | C1:3 | MD3 3 |
| 12 | Green | 12 | Airhead Inclinomter Pin 4 | | C1:10 | MD3 5 |

4RSPH65LAH (7)
BIN / AIR HEAD ELECTRONIC LEVELING

| PLUG 4 | | | | | | |
|---------------|-------|----|--------------------------------------|-------|---------|----|
| 1 | Red | 5 | Ground Drive Joystick -VBB Pin VS- | C1:28 | XA2 (1) | 42 |
| 2 | Clear | 5 | Ground Drive Joystick GND Pin GND | C1:15 | XA2 (1) | 31 |
| 3 | Black | 5 | Ground Drive Joystick Signal Pin SIG | C1:12 | XA2 (1) | 27 |
| 4 | Black | 7 | Port A Transducer Signal Pin 1 | C2:2 | MD3 | 9 |
| 5 | Red | 7 | Port A Transducer +VREF Pin 2 | C2:8 | MD3 | 17 |
| 6 | White | 7 | Port A Transducer -VREF Pin 3 | C2:5 | MD3 | 13 |
| 7 | Black | 10 | Port B Transducer Signal Pin 1 | C2:3 | MD3 | 10 |
| 8 | Red | 10 | Port B Transducer +VREF Pin 2 | C2:8 | MD3 | 17 |
| 9 | White | 10 | Port B Transducer -VREF Pin 3 | C2:5 | MD3 | 14 |
| 10 | | | | | | |
| 11 | | | | | | |
| 12 | | | | | | |

| PLUG 5 | | | | | | |
|---------------|--------|---------|-------------------|-------|---------|----|
| 1 | Red | 75 (4) | Auto Select | C2:4 | MD3 | 11 |
| 2 | Orange | 72 (4) | Bin Manual Up | C2:9 | MD3 | 18 |
| 3 | Blue | 71 (4) | Bin Manual Down | C2:10 | MD3 | 19 |
| 4 | White | 41 (4) | Travel Mode Input | C2:11 | MD3 | 20 |
| 5 | Red | 115 | Clutch Valve | C1:39 | XA2 | 49 |
| 6 | White | 371 (4) | System Error | C1:9 | XA2 (1) | 24 |
| 7 | Black | 12 (2) | Hi / Lo | C1:16 | XA2 (1) | 31 |
| 8 | Black | 01 (2) | 4X4 On /Off | C1:25 | XA2 (1) | 37 |
| 9 | Black | 001 (P) | 4X4 / XA2 Relays | C1:23 | XA2 (1) | 38 |
| 10 | Green | 605 | Airhead RPM Input | C1:24 | XA2 (1) | 39 |
| 11 | Green | 605 (4) | Airhead RPM Out | C1:24 | XA2 (1) | 39 |
| 12 | Red | 15 | XM - Pin 3 - N.O. | C1:39 | XA2 (1) | 49 |

| PLUG 6 | | | | | | |
|---------------|-------|-----|----------------------------|-------|---------|----|
| 1 | White | 13 | Airhead Pitch Coil 1 Pin A | C1:2 | XA2 (2) | 51 |
| 2 | Green | 13 | Airhead Pitch Coil 1 Pin B | C1:16 | XA2 (2) | 61 |
| 3 | Black | 13 | Airhead Pitch Coil 2 Pin A | C1:2 | XA2 (2) | 51 |
| 4 | Red | 13 | Airhead Pitch Coil 2 Pin B | C1:30 | XA2 (2) | 72 |
| 5 | White | 14 | Airhead Roll Coil 1 Pin A | C1:3 | XA2 (2) | 52 |
| 6 | Green | 14 | Airhead Roll Coil 1 Pin B | C1:17 | XA2 (2) | 62 |
| 7 | Black | 14 | Airhead Roll Coil 2 Pin A | C1:3 | XA2 (2) | 52 |
| 8 | Red | 14 | Airhead Roll Coil 2 Pin B | C1:31 | XA2 (2) | 73 |
| 9 | | | | | | |
| 10 | | | | | | |
| 11 | Red | 028 | +BATT | C1:28 | XA2 (2) | 68 |
| 12 | Black | 015 | -BATT | C1:15 | XA2 (2) | 59 |

4RSPH65LAH (7)
BIN / AIR HEAD ELECTRONIC LEVELING

PLUG 7 Small Gray Plug

| | | | | | | | |
|----|------|----|---------|----------------------------------|-------|------|---|
| 1 | Gray | 1 | -BATT | Bin Sensor (Blue 1) | C1:1 | MD3 | 1 |
| 2 | Gray | 2 | CAN-A L | To XA2 (1) C1:40 / XA2 (2) C1:40 | C1:2 | MD32 | 2 |
| 3 | Gray | 3 | CAN-B-L | Airhead Inclinometer Pin 3 | C1:3 | MD3 | 3 |
| 4 | | | | | | | |
| 5 | | | | | | | |
| 6 | | | | | | | |
| 7 | Gray | 7 | +RTC | | C1:7 | MD3 | 4 |
| 8 | | | | | | | |
| 9 | | | | | | | |
| 10 | Gray | 10 | CAN-B H | Airhead Inclinometer Pin 4 | C1:10 | MD3 | 5 |
| 11 | Gray | 11 | CAN-A-H | To XA2 (1) C1:26 / XA2 (2) C1:26 | C1:11 | MD3 | 6 |
| 12 | Gray | 12 | +BATT | | C1:12 | MD3 | 7 |

PLUG 8 Small Black Plug

| | | | | | | | |
|----|-------|----|--------|--|-------|------------|---------|
| 1 | Black | 1 | VIN-A | Motor Control (psi) Transducer Pin 1 | C2:1 | MD3 | 8 |
| 2 | Black | 2 | VIN-B | A-Port (psi) Transducer Pin 1 | C2:2 | MD3 | 9 |
| 3 | Black | 3 | VIN-C | B-Port (psi) Transducer Pin 1 | C2:3 | MD3 | 10 |
| 4 | Black | 4 | DIN-D | Auto Mode Switch / Bin Sensor (Brown) | C2:4 | MD3 | 11 / 12 |
| 5 | Black | 5 | VREF | MC2 Comm Cable (Black)/A-Port Trans Pin 3 (White 7)/ B-Port Trans Pin 3 (White 10)/Motor Control Trans Pin 3 (White 11) | C2:5 | MI 13 / 14 | |
| 6 | Black | 6 | USB-D | MC2 Comm Cable (White) | C2:6 | MD3 | 15 |
| 7 | Black | 7 | USB-D+ | MC2 Comm Cable (Green) | C2:7 | MD3 | 16 |
| 8 | Black | 8 | +VREF | A Port Trans Pin 2 (Red 7)/B Port Trans Pin 2 (Red 11)/ Motor Control Trans Pin 2 (Red 11) | C2:8 | MD3 | 17 |
| 9 | Black | 9 | DIN-E | Bin Manual Up (Orange 72) | C2:9 | MD3 | 18 |
| 10 | Black | 10 | DIN-F | Bin Manual Down (Blue 71) | C2:10 | MD3 | 19 |
| 11 | Black | 11 | DIN-G | Travel Mode Input (White 41) | C2:11 | MD3 | 20 |
| 12 | | | | | | | |

4RSPH65LAH (7)
BIN / AIR HEAD ELECTRONIC LEVELING

PLUG 9

| | | | | | | | |
|----|-------|--------|--|-------------|-------|----------|----|
| 1 | Red | 15 | Left Load Cell (Red) +Supply Pin 1 | +VREF | C1:42 | XA2 (2) | 75 |
| 2 | Clear | 15 | Left Load Cell (Yellow) +Output Pin 2 | VIN-E | C1:24 | XA2 (2) | 65 |
| 3 | Black | 15 | Left Load Cell (Black) -Supply Pin 3 | -VREF | C1:29 | XA2 (2) | 70 |
| 4 | Red | 16 | Right Load Cell (Red) +Supply Pin 1 | +VREF | C1:42 | XA2 (2) | 75 |
| 5 | Clear | 16 | Right Load Cell (Yellow) +Output Pin 2 | VIN-F | C1:25 | XA2 (20) | 66 |
| 6 | Black | 16 | Right Load Cell (Black) -Supply Pin 3 | -VREF | C1:29 | XA2 (2) | 70 |
| 7 | Clear | 17 | Left Primary Pump Coil 1 Pin "A" | COUT-C | C1:4 | XA2 (2) | 53 |
| 8 | Black | 17 | Left Primary Pump Coil 1 Pin "B" | COUT-C RET+ | C1:1 | XA2 (2) | 63 |
| 9 | Clear | 18 | Right Primary Pump Coil 1 Pin "A" | COUT-D | C1:5 | XA2 (2) | 54 |
| 10 | Black | 18 | Right Primary Pump Coil 1 Pin "B" | COUT-D RET+ | C1:1 | XA2 (2) | 64 |
| 11 | | | | | | | |
| 12 | White | 11 (4) | Load Cell Enable Signal | DIN-B | C1:11 | XA2 (2) | 56 |

PLUG 10

| | | | | | | | |
|----|---------------|-----|---|-------------|-------|---------|----|
| 1 | Black / White | (6) | Primaries On - Off Signal | DIN-A | C1:10 | XA2 (2) | 55 |
| 2 | Red | (6) | Left Primary Potentiometer Pin 1 | -VREF | C1:29 | XA2 (2) | 71 |
| 3 | Blue / White | (6) | Left Primary Potentiometer Pin 2 | VIN-C | C1:12 | XA2 (2) | 57 |
| 4 | Green / White | (6) | Left Primary Potentiometer Pin 3 | +VREF | C1:42 | XA2 (2) | 76 |
| 5 | Red / White | (6) | Right Primary Potentiometer Pin 1 | -VREF | C1:29 | XA2 (2) | 71 |
| 6 | Blue / Black | (6) | Right Primary Potentiometer Pin 2 | VIN-D | C1:13 | XA2 (2) | 58 |
| 7 | Red / Black | (6) | Right Primary Potentiometer Pin 3 | +VREF | C1:42 | XA2 (2) | 76 |
| 8 | | | | | | | |
| 9 | Green | 19 | Rear Ground Drive Pump Coil 2 Pin A Forward | COUT-F | C1:7 | XA2(1) | 77 |
| 10 | Red | 19 | Rear Ground Drive Pump Coil 2 Pin B Forward | COUT-F RET+ | C1:21 | XA2(1) | 78 |
| 11 | Black | 19 | Rear Ground Drive Pump Coil 1 Pin A Reverse | COUT-F | C1:7 | XA2(1) | 77 |
| 12 | White | 19 | Rear Ground Drive Pump Coil 1 Pin B Reverse | COUT-F RET- | C1:35 | XA2(1) | 79 |

ADJUSTMENT GROUP
 PRIMARIES

ON/OFF

LOAD CELL

ON/OFF

X A Z C 1

NODE B L A T E

NODE C R A T

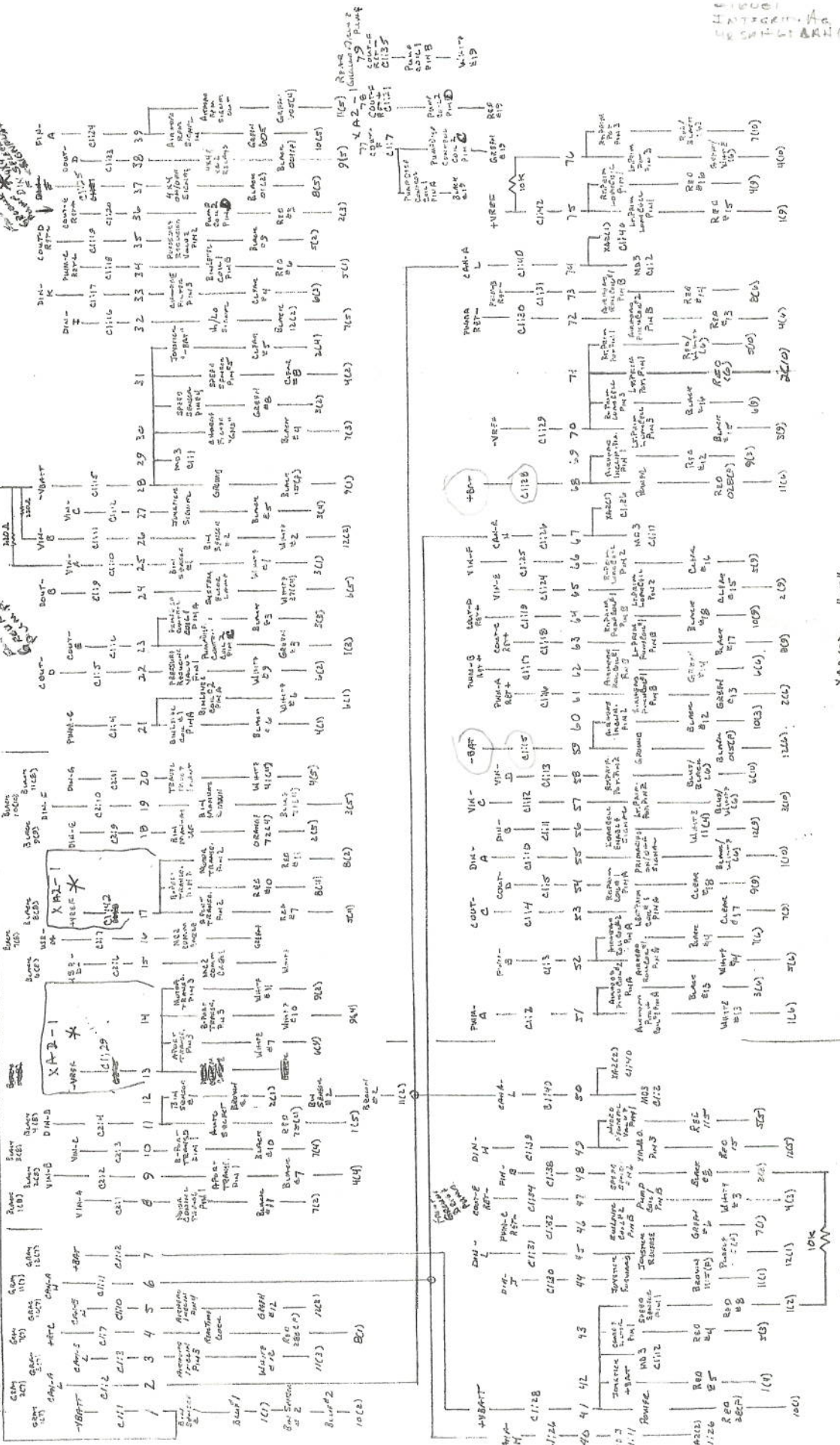

X A Z C 2

N O D E B L A T E

N O D E C R A T

17

41
42
43
44
45
46
47
48
49
50