

Lavresque

4RSPH W/65" AH

#~~05007~~ 05007

- ④  
TF2540-3  
2 1/2" CLS N/A BK140  
2 3/4" L20-40B  
FT250  
\* 35VQTBS  
2-400mm
- ③  
3" X 2" Bush  
2" CLS N/A BK132  
V500P-32  
FT200  
FT200  
V500P-32  
2" CLS N/A  
2" 90° STEEL  
W43-32PK  
ZDF2215-25-5  
W43-32PK  
2" 90° STEEL  
2" CLS N/A  
V500P-32  
2" CLS N/A  
2" TEE
- X 2" X 1 1/4" Bush  
O 2" 90° STEEL  
FT125  
2" X 1 1/4" Bush  
FT125
- \* T64/64 \* L4EE

- ③  
TF2030-3  
2" CLS N/A BK132  
V500P-32  
2" X 1 1/2" Bush  
X 2" X 1 1/2" Bush  
BK32432  
FT150
- \* PVEZIL  
\* TRIPLE COMM  
O 2" 90° STEEL  
2" X 1 1/2" Bush  
FT150
- \* TRIPLE COMM.

- ③  
TF2030-3  
2" CLS N/A  
V500P-32  
2" CLS N/A  
2" TEE  
X 2" X 1 1/2" Bush  
FT150
- \* TANDEM PLP  
O 2" 90° STEEL  
2" X 1 1/2" Bush  
BK31632  
FT100
- \* V10

- ④  
4" X 2" Bush  
2" CLS N/A  
V500P-32  
2" X 1 1/2" Bush  
1 1/2" CLS N/A  
5 FT150-25-5  
1 1/2" CLS N/A  
2" X 1 1/2" Bush  
V500P-32  
2" TEE
- X 2" X 1 1/4" Bush  
FT125  
\* TANDEM 3.0EE  
O 2" 90° STEEL  
2" X 1 1/4" Bush  
FT125
- \* TANDEM 3.0EE

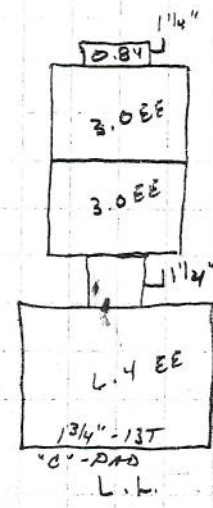
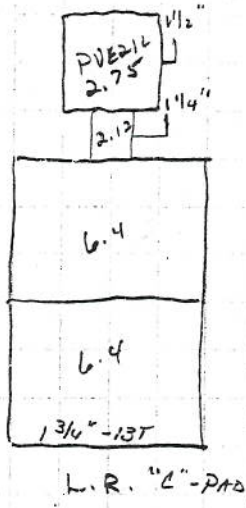

- L.R - TANDEM L.4 - GROUND DRIVE  
PVEZIL - STEERING CIRCUIT  
L.L. - L.4 EE - AIR HEAD  
TANDEM 3.0E - SECONDARY  
- ROCK CRUSHER  
T.R - 35VQTBS - CROSS  
S.OE  
TRIPLE COMMERCIAL - BIN FILL  
BIN UNLOAD  
LEFT STAR TABLE  
T.L. - TANDEM 3.0EE - LEFT PRIMARY  
RIGHT PRIMARY  
TANDEM PLP - RIGHT STAR TABLE  
- RIGHT STAR DIST. STAR  
- BRANCH CHANGE PRESSURE

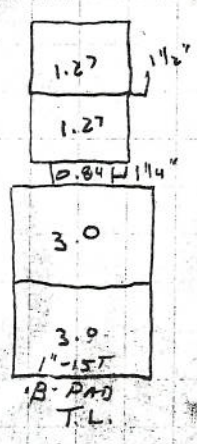
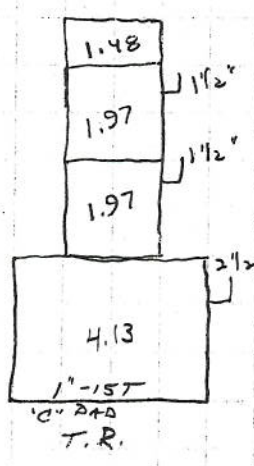

- ENG - V10  
3 - 1" LOCK COLLAR  
3 - 2015-002 INTAKE FILTER ASSY  
~~1 - 2" CAP BK1132~~

GEAR PRODUCTS - 4/10/65 BOX  
DP49

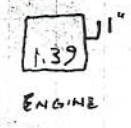

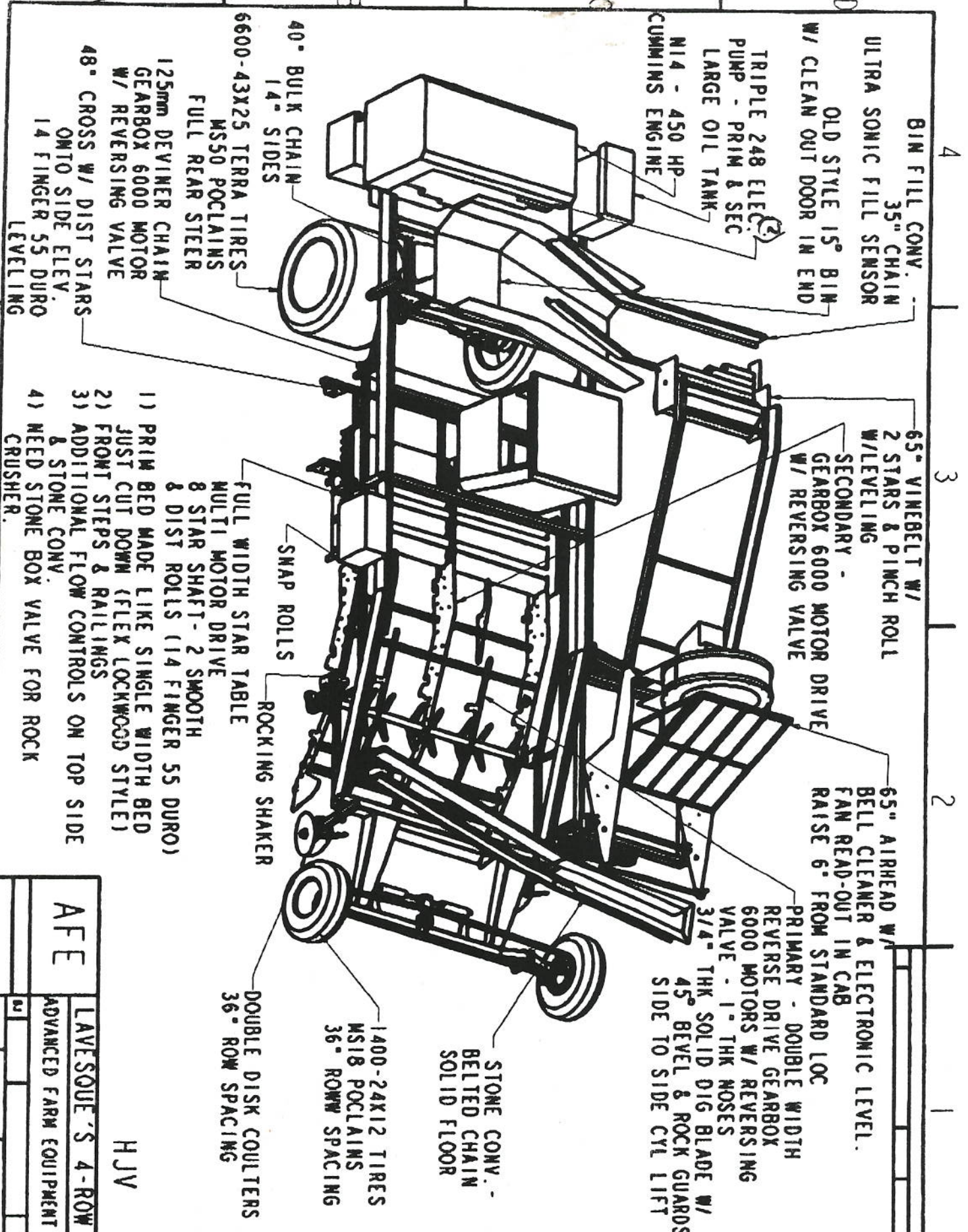

BIN FILL CONV.

35" CHAIN  
ULTRA SONIC FILL SENSOR  
W/ CLEAN OUT DOOR IN END

OLD STYLE 15" BIN

TRIPLE 248 ELEC.  
PUMP - PRIM & SEC  
LARGE OIL TANK

M14 - 450 HP  
CUMMINS ENGINE

40" BULK CHAIN  
14" SIDES

6600-43X25 TERRA TIRES  
MSSO POCLAINS  
FULL REAR STEER

125mm DEVINER CHAIN  
GEARBOX 6000 MOTOR  
W/ REVERSING VALVE

48" CROSS W/ DIST STARS  
OMTO SIDE ELEV.  
14 FINGER 55 DURO  
LEVELLING

65" VINEBELT W/  
2 STARS & PINCH ROLL  
W/LEVELLING  
SECONDARY -  
GEARBOX 6000 MOTOR DRIVE  
W/ REVERSING VALVE

65" AIRHEAD W/  
BELL CLEANER & ELECTRONIC LEVEL.  
FAN READ-OUT IN CAB  
RAISE 6" FROM STANDARD LOC

PRIMARY - DOUBLE WIDTH  
REVERSE DRIVE GEARBOX  
6000 MOTORS W/ REVERSING  
VALVE - 1" THK NOSES  
3/4" THK SOLID DIG BLADE W/  
45° BEVEL & ROCK GUARDS  
SIDE TO SIDE CYL LIFT

STONE CONV.  
BELTED CHAIN  
SOLID FLOOR

1400-24X12 TIRES  
MS18 POCLAINS  
36" ROWW SPACING

DOUBLE DISK COULTERS  
36" ROW SPACING

SNAP ROLLS  
ROCKING SHAKER

FULL WIDTH STAR TABLE  
MULTI MOTOR DRIVE  
8 STAR SHAFT - 2 SMOOTH  
& DIST ROLLS (14 FINGER 55 DURO)

- 1) PRIM BED MADE LIKE SINGLE WIDTH BED  
JUST CUT DOWN (FLEX LOCKWOOD STYLE)
- 2) FRONT STEPS & RAILINGS
- 3) ADDITIONAL FLOW CONTROLS ON TOP SIDE  
& STONE CONV.
- 4) NEED STONE BOX VALVE FOR ROCK  
CRUSHER.

AFF

HJV

LAVESQUE'S 4-ROW  
ADVANCED FARM EQUIPMENT

4

4

3

2

3

2

A

C

C

LAVESQUE 024585

HYDRAZOL

HYDTB 06	HYDTB 1/2	HYDTB 5/8	HYDTB 7/8	HYDTB 14	HYDTB 16	113120	EMT050	EMT075
84	70	240	48		50	34	36	85
76	72	240	88		88	23	48	46
142	67	240	12		12	18	38	85
50	144	240	175		129	40	25	81
50	74	42	<del>175</del>		67	39	8	53
55	72	41	189		168	18	22	33
53	51		129		189	18	23	104
	58		144		189	21	67	104
42.5	196	86.911	88		240	12	27	104
	106		86			16	22	59
	200		76			13	53	79
	40		76		74.333	10	30	26
	39		230			22	19	60
	62		230			48	10	27
	132		240			15	112	63
	130		108			8	32	25
	118		141			28	8	46
	118		140			8	11	9
	118		107			17	14	34
	112		140			48	18	
	110		133			5	115	97.583
	108		68				18	
	106		69			38.777	31	
	104		240				28	
			240				62	
			240				62	
	199.8		238				62	
			236				36	
			234				44	
			60				41	
			99				48	
			136				120	
			134				40	
			97				22	
			93				394	
			90				24	
			191				24	
			90				65	
			80				27	
							27	
							27	
			434.583				94	
							17	
							12	
							18	
							48	
							22	
							23	
							24	
							34	
							18	
							43	

178.583

024585  
LAVESQUE

BinNum ItemId Descr

04-G	30015-019	Airhead Cleaner Valve Bracket	
04-G	30023-700	1/4" x 5" Dock Washer	
04-G	6432k25-2	1" Set Collar w/2 Set screws	
04-G	6432K29	1 1/4" Set Screw Collar	
04-G1	30009-019	RDRS 112 Mounting Bracket	
04-G1	30012-019	CRV5 Bracket	
04-G1	30014-019	HFP 1637 Bracket	
04-G2	30000-019	STS Valve Bracket	
04-G2	30003-019	DTS-0198 Mounting Bracket	
04-G2	30004-019	DTS-0150 Bracket	
04-G2	30016-019	RV1H & L Bracket	
04-G2	30017-019	Rear Steering Valve Bracket	
04-G2	30018-019	Double Filter Head Mounting Bracket	
04-G3	30019-019	2 Section Valve Bank Bracket	
04-G3	30021-019	4 Section Valve Bank	
04-G3	30023-019	DTS 2297 Mounting Bracket	
04-G3	30029-019	SV4-10 Mounting Bracket	
04-G3	30031-019	Fuel Pump Bracket	
04-G3	30032-019	HFP 9053T Mounting Bracket	
04-G4	30005-019	HFP 1645 Mounting Bracket	
04-G4	30025-019	DTS 0197 Mounting Bracket	
04-G4	30027-019	RDRS 112 Star Roll Mounting Bracket	
04-G4	30033-019	SV1-16 Mounting Bracket	
04-G4	30034-019	MV4 Mounting Bracket	FAB
04-G4	30035-019	RDRS112 Distributor Roll Mounting	
04-G5	30000-014	Work Light Bracket <i>OBSOLETE</i>	
04-G5	30001-014	Back Up Lights Bracket / <i>work light</i>	FAB
04-G5	30009-022	High Pressure Fairey Filter Bracket	
04-G5	30010-022	Long High Pressure Filter Bracket	
04-G5	30036-019	DTS-0032 Mounting Bracket	
04-G6	30024-014	Fuel Filter Bracket	
04-G6	30024-019	DTS4276 Mounting Bracket	
04-G6	30028-019	Reversing Valve Mounting Bracket	
04-G6	30040-019	MCV2 Mounting Bracket	
04-G7	30001-019	Flow Divider Plate	
04-G8	30026-019	MV4 Mounting Bracket	
04-G8	30048-019	Bracket for CDC 0126	

024585  
LAVESQUE

BinNum	ItemId	Descr	
04-F	30017-022	Rear Light Mount LH	
04-F3	2004-03	Cab Mount	
04-F5	12363	NAPA Oil Seal (Steering Sensor Box)	
04-F5	30002-023	Oil Seal Ring	
04-F5	30003-023	(3/4 x 3/4 x 1) Push Block	
04-F5	30004-023	(1/4x3x7 1/2) End Cap	
04-F5	30005-023	(1/4x3x7 1/2)End Cap Oil Seal End	
04-F5	30006-023	(3/4x2x2 1/2) Sensor Block	
04-F5	30007-023	(3/4x2 1/2x 7 1/2) Brass Mounts	
04-F5	30008-023	Steering Sensor Rod	
04-F5	30009-023	1/2 x2x3 1/2 Linkage Tab	
04-F5	30010-023	1/2x1 1/2x 4 Linkage Tab	
04-F5	30061-023	5" Sensor Adjuster	
04-F5	30062-023	4" Sensor Adjuster	
04-F5	30063-023	8" Linkage	
04-F5	30064-023	1/8x2x2 Angle	
04-F6	30003-700	2" Threaded Spacer	
04-F6	30004-700	1 1/8" Threaded Spacer	
04-F6	30006-002	Bulk Loader Bushing	
04-F6	30025-700	Threaded Spacer 1 1/2"	
04-F7	30002-019	DTS-0373 Bracket	
04-F8	30008-019	DTS 0287 Mounting Bracket	
04-F8	30039-015	Engine Mount Pads	
04-F12	30004-037	Press Bar Mounting Bracket	
04-F15	30034-015	Battery Box	
04-F16	30002-041	9" Vibrator Plates	
04-F17	30000-041	Vibrator Plate (Small)	
04-FTOP	40001-019	Hooded Valve Bank Assy	
	30068-019	SINGLE FILTER MOUNT	
	30069-019	DOUBLE FILTER MOUNT	
	30057-019	DTS 0155 BRKT	FAB

# Detail List

LAVESQUE

Part#	Description	Qty
100037	3/8" Steel Line Clamp	VII V IIII
100050	1/2" Steel Line Clamp	III IIII IIII - III XV XXXII
100062	5/8" Steel Line Clamp	25
100087	7/8" Steel Line Clamp	XXXXXXXXXXXXXXXXX V IIII II
100100	1" Steel Line Clamp	XV IIII III IIII II
100125	1 1/4" Steel Line Clamp	
100150	1 1/2" Steel Line Clamp	
100200	2" Steel Line Clamp	
100225	2 1/4" Steel Line Clamp	
100250	2 1/2" Steel Line Clamp	
ABAX1000-06 20006-011	Straight Tube Adapter to JIC Male #6	III IIII IIII
ABAX1000-08 20005-011	Straight Tube Adapter to JIC Male #8	III IIII IIII IIII IIII IIII IIII XV
ABAX1000-10 20007-011	Straight Tube Adapter to JIC Male #10	III IIII IIII
ABAX1000-14-12 20010-011	Strght Tube Adptr to JIC Male #14-12	III IIII V XX III XV III III III III
ABAX1000-16 20009-011	Straight Tube Adapter to JIC Male #16	V IIII IIII
BA19-06	3/8" Replacement Sleeve	
BA19-08	1/2" Replacement Sleeve	
BA19-10	5/8" Replacement Sleeve	
BA19-14	7/8" Replacement Sleeve	
BA19-16	1" Replacement Sleeve	
BAX1100 06	3/8" NPT Female x 3/8" Tube	
BAX1100 08	1/2" NPT Female x 5/8" Tube	
BAX1100 10	1/2" NPT Female x 5/8" Tube	
BAX1100 14	3/4" NPT Female x 7/8" Tube	
BAX1200 06	3/8" Tube Union	
BAX1200 08	1/2" Tube Union	
BAX1200 10	5/8" Tube Union	
BAX1200 14	7/8" Tube Union	III
BAX1200 16	1" Tube Union	II
BAX3100 06	3/8" NPT x 3/8" Tube Tee	
BAX3100 08	1/2" NPT x 1/2" Tube Tee	III
BAX3100 10	1/2" NPT x 5/8" Tube Tee	
BAX3100 14	3/4" NPT x 7/8" Tube Tee	
BAX3100 16	1" NPT x 1" Tube Tee	
BAX3200 08	1/2" Tube Tee	II
BAX3200 14	7/8" Tube Tee	I
BAX3200 16	1" Tube Tee	I

# dBrown

OF DETROIT  
INCORPORATED

POWER TRANSMISSION  
COVER SPECIALISTS  
SAGINAW • DETROIT  
GRAND RAPIDS

10	1/4-20 x 2 1/4 HACS
121	1/4-20 x 3" HACS
126	1/4" FLAT WASHER
9	5/16-18 x 1 1/2 HACS
11	5/16-16 Lock WASHER
8	3/8-16 x 1" HACS
8	3/8-16 x 3/4" HACS
8	3/8-16 NUT
8	3/8 Lock WASHER

58  
126  
126

1646 CHAMPAGNE DRIVE N. • SAGINAW, MI 48604 • PHONE: (989) 771-0200 • FAX: (989) 771-0700  
1500 SUPERIOR PARKWAY • WESTLAND, MI 48185 • PHONE: (734) 722-8900 • FAX: (734) 722-8910  
4750 BARDEN CT. • GRAND RAPIDS, MI 49512 • PHONE: (616) 656-0500 • FAX: (616) 656-9997

"FAST DEPENDABLE SERVICE"



*LAVESQUE*

**Advanced Farm Equipment  
Item Usage Report**

Item Code	Description	Item Used In Assembly	Description	UOM	Quantity
20000-002	Decal-Overhead Wing Hazard (SW	45007-636	Other Finish Assy 05007 La Ves	each	4.000
20001-002	Large Lenco Logo	45007-636	Other Finish Assy 05007 La Ves	each	4.000
20002-002	Small Lenco Logo	45007-636	Other Finish Assy 05007 La Ves	each	4.000
20003-002	Warning - Rotating Part Hazard	45007-636	Other Finish Assy 05007 La Ves	each	4.000
20003-010	Airhead Gear Box	45007-636	Other Finish Assy 05007 La Ves	each	1.000
20004-001	Large Actuator 6" stroke	45007-636	Other Finish Assy 05007 La Ves	each	1.000
20004-002	Warning - Moving Part Hazard	45007-636	Other Finish Assy 05007 La Ves	each	2.000
20005-002	Danger-To Prevent Serious Inju	45007-636	Other Finish Assy 05007 La Ves	each	14.000
20008-002	AFE Serial # Tag	45007-636	Other Finish Assy 05007 La Ves	ea	2.000
20008-019	<i>2035-01018</i> 3 1/2" Rubber NO Flange	45007-636	Other Finish Assy 05007 La Ves	each	12.000
20009-002	High Pressure Fluid Hazard	45007-636	Other Finish Assy 05007 La Ves	ea	2.000
20009-018	60 Roller Chain	45007-636	Other Finish Assy 05007 La Ves	ft	3.000
20009-019	<i>2035-01017</i> 3 1/2" Rubber w/5" Flange	45007-636	Other Finish Assy 05007 La Ves	each	2.000
		45007-636	Other Finish Assy 05007 La Ves	each	2.000
		45007-636	Other Finish Assy 05007 La Ves	each	2.000
20009-020	Paraflex Element	45007-636	Other Finish Assy 05007 La Ves	each	1.000
20010-002	Thrown Object Hazard	45007-636	Other Finish Assy 05007 La Ves	ea	3.000
20010-018	Connector Link for 60 Chain	45007-636	Other Finish Assy 05007 La Ves	each	1.000
20010-020	PX120 Paraflex Flange	45007-636	Other Finish Assy 05007 La Ves	each	2.000
20011-002	Main AFE Decal - 8"x18"	45007-636	Other Finish Assy 05007 La Ves	ea	2.000
20011-018	Offset Link for 60 Chain	45007-636	Other Finish Assy 05007 La Ves	each	1.000
20012-019	<i>2035-01009</i> 3 1/2" Steel W/5" Flange	45007-636	Other Finish Assy 05007 La Ves	ea	2.000
		45007-636	Other Finish Assy 05007 La Ves	ea	6.000
		45007-636	Other Finish Assy 05007 La Ves	ea	12.000
		45007-636	Other Finish Assy 05007 La Ves	ea	2.000
		45007-636	Other Finish Assy 05007 La Ves	ea	2.000
		45007-636	Other Finish Assy 05007 La Ves	ea	4.000
		45007-636	Other Finish Assy 05007 La Ves	ea	4.000
		45007-636	Other Finish Assy 05007 La Ves	ea	4.000
20012-029	220 Belting 3/8" x 36"	45007-636	Other Finish Assy 05007 La Ves	sqft	54.000
		45007-636	Other Finish Assy 05007 La Ves	sqft	12.000
20017-030	42mm 4 Bolt Chain Clip - Noffs	45007-636	Other Finish Assy 05007 La Ves	ea	2.000

*1-27  
6  
33*

*36*

*NO*

Advanced Farm Equipment  
Item Usage Report

Item Code	Description	Item Used In Assembly	Description	UOM	Quantity
20019-019	2035-07002 1.5" Roller Standoff	45007-636	Other Finish Assy 05007 La Ves	each	6.000
		45007-636	Other Finish Assy 05007 La Ves	each	3.000
		45007-636	Other Finish Assy 05007 La Ves	each	8.000
		45007-636	Other Finish Assy 05007 La Ves	each	4.000
		45007-636	Other Finish Assy 05007 La Ves	each	4.000
		45007-636	Other Finish Assy 05007 La Ves	each	13.000
		45007-636	Other Finish Assy 05007 La Ves	each	67.000
		45007-636	Other Finish Assy 05007 La Ves	each	4.000
		45007-636	Other Finish Assy 05007 La Ves	each	12.000
20030-026	John Deere Cab Assembly	45007-636	Other Finish Assy 05007 La Ves	each	1.000
20032-006	3/4" Heater Hose	45007-636	Other Finish Assy 05007 La Ves	ft	18.000
20033-006	5/8" Heater Hose	45007-636	Other Finish Assy 05007 La Ves	ft	18.000
20033-019	2035-03001 4" Steel Carrier	45007-636	Other Finish Assy 05007 La Ves	each	16.000
20036-006	5/8" Hose Clamp	45007-636	Other Finish Assy 05007 La Ves	each	2.000
20037-006	3/4" Hose Clamp	45007-636	Other Finish Assy 05007 La Ves	each	2.000
20039-001	Electric Fuel Pump	45007-636	Other Finish Assy 05007 La Ves	each	1.000
20054-019	2035-01011 3 1/2" Rubber w/5" Flange	45007-636	Other Finish Assy 05007 La Ves	each	2.000
20056-019	2035-04001 Nose Cone Roller--Tapered	45007-636	Other Finish Assy 05007 La Ves	ea	4.000
20061-014	20ft Control Cable	45007-636	Other Finish Assy 05007 La Ves	each	1.000
20061-019	2035-01012 3 1/2" Rubber w/8" Flange	45007-636	Other Finish Assy 05007 La Ves	each	1.000
20062-001	Battery Nuts	45007-636	Other Finish Assy 05007 La Ves	each	4.000
20062-019	2035-01010 3 1/2" Rubber No Flange	45007-636	Other Finish Assy 05007 La Ves	ea	2.000
		45007-636	Other Finish Assy 05007 La Ves	ea	4.000
20063-014	24' Control Cable	45007-636	Other Finish Assy 05007 La Ves	ea	1.000
20064-001	Battery	45007-636	Other Finish Assy 05007 La Ves	ea	2.000
20075-006	Threaded Ball Joint (Ground Dr	45007-636	Other Finish Assy 05007 La Ves	each	6.000
20075-019	2035-00007 4" Rubber Roller	45007-636	Other Finish Assy 05007 La Ves	ea	12.000
		45007-636	Other Finish Assy 05007 La Ves	ea	4.000
		45007-636	Other Finish Assy 05007 La Ves	ea	3.000
		45007-636	Other Finish Assy 05007 La Ves	ea	4.000
		45007-636	Other Finish Assy 05007 La Ves	ea	4.000
		45007-636	Other Finish Assy 05007 La Ves	ea	8.000
		45007-636	Other Finish Assy 05007 La Ves	ea	6.000
		45007-636	Other Finish Assy 05007 La Ves	ea	33.000
20076-019	2035-00008 5" Rubber Roller	45007-636	Other Finish Assy 05007 La Ves	ea	16.000

121

16.000

2.000

6

14

Advanced Farm Equipment  
Item Usage Report

Item Code	Description	Item Used In Assembly	Description	UOM	Quantity
		45007-636	Other Finish Assy 05007 La Ves	ea	8.000
20077-019	3 1/2" Rubber Roller W/5" Flng	45007-636	Other Finish Assy 05007 La Ves	ea	25.000
	2035-01015				
20078-019	3 1/2" Rubber Roller	45007-636	Other Finish Assy 05007 La Ves	ea	20.000
	2035-01016				
20080-019	Roller Idler 3 1/2	STEEL NO FLANGE	Other Finish Assy 05007 La Ves	ea	12.000
	2035-01008				
		45007-636	Other Finish Assy 05007 La Ves	ea	1.000
		45007-636	Other Finish Assy 05007 La Ves	ea	4.000
		45007-636	Other Finish Assy 05007 La Ves	ea	2.000
		45007-636	Other Finish Assy 05007 La Ves	ea	2.000
20081-019	Roller W/Short Standoff	4" steel	Other Finish Assy 05007 La Ves	ea	4.000
	2035-03000				
20262-001	2/0 Welding Cable	45007-636	Other Finish Assy 05007 La Ves	ft	22.200
20263-001	Battery Lug 3/0 3/8" Eye	45007-636	Other Finish Assy 05007 La Ves	each	12.000
20264-001	Battery Lug 3/0 1/2" Eye	45007-636	Other Finish Assy 05007 La Ves	each	8.000
21007-018	2012 Taperlock 1 1/4" Bore	45007-636	Other Finish Assy 05007 La Ves	each	1.000
21009-018	2012 Taperlock 2" Bore	45007-636	Other Finish Assy 05007 La Ves	each	1.000
22004-023	Fuel Filter	45007-636	Other Finish Assy 05007 La Ves	each	1.000
22005-023	Fuel Filter Base	45007-636	Other Finish Assy 05007 La Ves	each	1.000
22800-019	Sprocket 28mm 12 Tooth 1 1/4"	SC	Other Finish Assy 05007 La Ves	each	2.000
24200-019	42mm 10 Tooth 1 1/4" Bore	45007-636	Other Finish Assy 05007 La Ves	each	2.000
24500-019	45mm 10 Tooth 1 1/4" Bore	45007-636	Other Finish Assy 05007 La Ves	each	2.000
		45007-636	Other Finish Assy 05007 La Ves	each	2.000
24501-019	45mm 10 Tooth 2" Bore	45007-636	Other Finish Assy 05007 La Ves	each	3.000
		45007-636	Other Finish Assy 05007 La Ves	each	6.000
24502-019	45mm 10 Tooth 1 1/4" Bore	45007-636	Other Finish Assy 05007 La Ves	each	2.000
25040-019	50mm 14 Tooth 2" Bore 1/2" Cha	45007-636	Other Finish Assy 05007 La Ves	each	14.000
26121-018	60 Chain 12 Tooth 1 1/4" Bore	45007-636	Other Finish Assy 05007 La Ves	each	1.000
		45007-636	Other Finish Assy 05007 La Ves	each	1.000
26132-018	AFE Economy Idler Sprocket	45007-636	Other Finish Assy 05007 La Ves	ea	2.000
		45007-636	Other Finish Assy 05007 La Ves	ea	1.000
26240-018	60 Chain 24 Tooth 2012 Taperlo	45007-636	Other Finish Assy 05007 La Ves	each	1.000
		45007-636	Other Finish Assy 05007 La Ves	each	1.000
2926	Red Grease (Wolf's Head)	45007-636	Other Finish Assy 05007 La Ves	ea	3.000
30018-019	Double Filter Head Mounting Br	45007-636	Other Finish Assy 05007 La Ves	each	1.000

**Advanced Farm Equipment  
Item Usage Report**

Item Code	Description	Item Used In Assembly	Description	UOM	Quantity
30020-014	M-11 Eng Block Throttle Cable	45007-636	Other Finish Assy 05007 La Ves	each	1.000
30041-019	Throttle Extention	45007-636	Other Finish Assy 05007 La Ves	each	1.000
30043-013	Wisc. Dbl Wide Dig. Blade	45007-636	Other Finish Assy 05007 La Ves	ea	2.000
40001-047	Tire & Rim Assy	45007-636	Other Finish Assy 05007 La Ves	each	2.000
40010-047	Tire & Rim Assy	45007-636	Other Finish Assy 05007 La Ves	each	2.000
665-1052	Clip On Nuts	45007-636	Other Finish Assy 05007 La Ves	ea	12.000
733-5775	U-Bolt	45007-636	Other Finish Assy 05007 La Ves	each	2.000
75-213	Gear Lube 80w90 5 Gal Pail	45007-636	Other Finish Assy 05007 La Ves	5 Ga	.500
AF	Anti-Freeze	45007-636	Other Finish Assy 05007 La Ves	ea	7.000
BTCR 3/8x1 1/2	3/8" x 1 1/2" Carriage Bolt	45007-636	Other Finish Assy 05007 La Ves	each	15.000
BTEL 1/4x1	1/4" x 1" Elevator Bolt	45007-636	Other Finish Assy 05007 La Ves	each	30.000
BTFW 1/2	1/2" Flat Washer	45007-636	Other Finish Assy 05007 La Ves	each	4.000
BTFW 3/8	3/8" Flat Washer	45007-636	Other Finish Assy 05007 La Ves	each	15.000
BTHH 1/2x1 1/2	1/2"-13 x 1 1/2" HHCS	45007-636	Other Finish Assy 05007 La Ves	each	24.000
BTHH 1/2x4	1/2"-13 x 4" HHCS	45007-636	Other Finish Assy 05007 La Ves	each	4.000
BTHH 3/8x1F	3/8"-24 x 1" HHCS	45007-636	Other Finish Assy 05007 La Ves	each	2.000
BTHH 5/8x3 1/2	5/8"-11 x 3 1/2" HHCS Bolt	45007-636	Other Finish Assy 05007 La Ves	each	4.000
		45007-636	Other Finish Assy 05007 La Ves	each	46.000
		45007-636	Other Finish Assy 05007 La Ves	each	7.000
		45007-636	Other Finish Assy 05007 La Ves	each	12.000
		45007-636	Other Finish Assy 05007 La Ves	each	6.000
		45007-636	Other Finish Assy 05007 La Ves	each	4.000
		45007-636	Other Finish Assy 05007 La Ves	each	7.000
		45007-636	Other Finish Assy 05007 La Ves	each	16.000
		45007-636	Other Finish Assy 05007 La Ves	each	5.000
		45007-636	Other Finish Assy 05007 La Ves	each	12.000
BTHH 5/8x4	5/8"-11 x 4" HHCS Bolt	45007-636	Other Finish Assy 05007 La Ves	each	10.000
		45007-636	Other Finish Assy 05007 La Ves	each	4.000
		45007-636	Other Finish Assy 05007 La Ves	each	12.000
BTHH 5/8x5	5/8"-11 x 5" HHCS Bolt	45007-636	Other Finish Assy 05007 La Ves	each	2.000
		45007-636	Other Finish Assy 05007 La Ves	each	2.000
BTHH 5/8x5 1/2	5/8"-11 x 5 1/2" HHCS	45007-636	Other Finish Assy 05007 La Ves	each	12.000
BTHH 5/8x6	5/8"-11 x 6" HHCS	45007-636	Other Finish Assy 05007 La Ves	each	6.000

Advanced Farm Equipment  
Item Usage Report

Item Code	Description	Item Used In Assembly	Description	UOM	Quantity
BTHH 5/8x7	5/8"-11 x 7" HHCS	45007-636	Other Finish Assy 05007 La Ves	each	15.000
BTHN 1/2	1/2"-13 Hex Nut	45007-636	Other Finish Assy 05007 La Ves	each	6.000
BTHN 1/4	1/4"-20 Hex Nut Gr 5 ZP	45007-636	Other Finish Assy 05007 La Ves	each	4.000
		45007-636	Other Finish Assy 05007 La Ves	each	24.000
		45007-636	Other Finish Assy 05007 La Ves	each	16.000
		45007-636	Other Finish Assy 05007 La Ves	each	30.000
		45007-636	Other Finish Assy 05007 La Ves	each	6.000
		45007-636	Other Finish Assy 05007 La Ves	each	160.000
		45007-636	Other Finish Assy 05007 La Ves	each	60.000
		45007-636	Other Finish Assy 05007 La Ves	each	18.000
BTHN 3/8	3/8"-16 Hex Nut	45007-636	Other Finish Assy 05007 La Ves	each	12.000
		45007-636	Other Finish Assy 05007 La Ves	each	34.000
		45007-636	Other Finish Assy 05007 La Ves	each	15.000
		45007-636	Other Finish Assy 05007 La Ves	each	15.000
		45007-636	Other Finish Assy 05007 La Ves	each	4.000
		45007-636	Other Finish Assy 05007 La Ves	each	24.000
		45007-636	Other Finish Assy 05007 La Ves	each	34.000
		45007-636	Other Finish Assy 05007 La Ves	each	16.000
BTLW 1/2	1/2" Lock Washer	45007-636	Other Finish Assy 05007 La Ves	each	6.000
		45007-636	Other Finish Assy 05007 La Ves	each	12.000
		45007-636	Other Finish Assy 05007 La Ves	each	18.000
		45007-636	Other Finish Assy 05007 La Ves	each	18.000
		45007-636	Other Finish Assy 05007 La Ves	each	60.000
		45007-636	Other Finish Assy 05007 La Ves	each	30.000
		45007-636	Other Finish Assy 05007 La Ves	each	30.000
		45007-636	Other Finish Assy 05007 La Ves	each	160.000
BTLW 1/4	1/4" Lock Washer	45007-636	Other Finish Assy 05007 La Ves	each	15.000
		45007-636	Other Finish Assy 05007 La Ves	each	2.000
		45007-636	Other Finish Assy 05007 La Ves	each	15.000
		45007-636	Other Finish Assy 05007 La Ves	each	10.000
		45007-636	Other Finish Assy 05007 La Ves	each	6.000
		45007-636	Other Finish Assy 05007 La Ves	each	150.000
		45007-636	Other Finish Assy 05007 La Ves	each	16.000
		45007-636	Other Finish Assy 05007 La Ves	each	36.000
BTLW 3/8	3/8" Lock Washer	45007-636	Other Finish Assy 05007 La Ves	each	12.000
		45007-636	Other Finish Assy 05007 La Ves	each	18.000
		45007-636	Other Finish Assy 05007 La Ves	each	60.000
		45007-636	Other Finish Assy 05007 La Ves	each	30.000
		45007-636	Other Finish Assy 05007 La Ves	each	30.000
		45007-636	Other Finish Assy 05007 La Ves	each	60.000
		45007-636	Other Finish Assy 05007 La Ves	each	30.000
		45007-636	Other Finish Assy 05007 La Ves	each	160.000
BTMS 1/4x1 1/4FH	1/4"-20 x 1 1/4"Phillips Mach	45007-636	Other Finish Assy 05007 La Ves	each	15.000
		45007-636	Other Finish Assy 05007 La Ves	each	2.000
		45007-636	Other Finish Assy 05007 La Ves	each	10.000
		45007-636	Other Finish Assy 05007 La Ves	each	6.000
		45007-636	Other Finish Assy 05007 La Ves	each	150.000
		45007-636	Other Finish Assy 05007 La Ves	each	16.000
		45007-636	Other Finish Assy 05007 La Ves	each	36.000
		45007-636	Other Finish Assy 05007 La Ves	each	12.000
BTMS 1/4x1FH	1/4"-20 x 1" Phillips Machine	45007-636	Other Finish Assy 05007 La Ves	each	18.000
		45007-636	Other Finish Assy 05007 La Ves	each	60.000
		45007-636	Other Finish Assy 05007 La Ves	each	60.000
		45007-636	Other Finish Assy 05007 La Ves	each	34.000
		45007-636	Other Finish Assy 05007 La Ves	each	34.000
		45007-636	Other Finish Assy 05007 La Ves	each	34.000
		45007-636	Other Finish Assy 05007 La Ves	each	34.000
		45007-636	Other Finish Assy 05007 La Ves	each	34.000
BTSH 1/2x1 1/4	1/2"-13 x 1 1/4" SHCS Alloy	45007-636	Other Finish Assy 05007 La Ves	each	2.000
		45007-636	Other Finish Assy 05007 La Ves	each	2.000
BTSMS 8x1/2HH	#8x1/2 Hex Head Sheet Metal Sc	45007-636	Other Finish Assy 05007 La Ves	each	2.000
		45007-636	Other Finish Assy 05007 La Ves	each	2.000
BTSN 5/8	5/8"-11 Spin Lock Nut	45007-636	Other Finish Assy 05007 La Ves	each	8.000
		45007-636	Other Finish Assy 05007 La Ves	each	4.000
		45007-636	Other Finish Assy 05007 La Ves	each	12.000
		45007-636	Other Finish Assy 05007 La Ves	each	9.000
		45007-636	Other Finish Assy 05007 La Ves	each	7.000
		45007-636	Other Finish Assy 05007 La Ves	each	7.000
		45007-636	Other Finish Assy 05007 La Ves	each	4.000

**Advanced Farm Equipment  
Item Usage Report**

Item Code	Description	Item Used In Assembly	Description	UOM	Quantity
		45007-636	Other Finish Assy 05007 La Ves	each	17.000
		45007-636	Other Finish Assy 05007 La Ves	each	16.000
DSR-2460	24" Coultter Blade	45007-636	Other Finish Assy 05007 La Ves	each	4.000
EMT075	3/4" EMT Conduit	45007-636	Other Finish Assy 05007 La Ves	ft	2.200
HDPE 04	1/4" HDPE Plastic	45007-636	Other Finish Assy 05007 La Ves	SQ F	15.000
		45007-636	Other Finish Assy 05007 La Ves	SQ F	12.300
HDPE 16	1" HDPE Plastic	45007-636	Other Finish Assy 05007 La Ves	SQ F	4.000
		45007-636	Other Finish Assy 05007 La Ves	SQ F	3.250
		45007-636	Other Finish Assy 05007 La Ves	SQ F	7.500
LEN-AFE	AFE Labor 1/4 Hour	45007-636	Other Finish Assy 05007 La Ves	1/4h	1,196.000
STFL 16x24	1" x 1 1/2" Flat Steel HR	45007-636	Other Finish Assy 05007 La Ves	ft	1.600
STKS 04	1/4" Steel Key Stock	45007-636	Other Finish Assy 05007 La Ves	ft	.300
		45007-636	Other Finish Assy 05007 La Ves	ft	.130
		45007-636	Other Finish Assy 05007 La Ves	ft	.300
STKS 05	5/16" Steel Key Stock	45007-636	Other Finish Assy 05007 La Ves	ft	.130
STKS 06	3/8" Steel Key Stock	45007-636	Other Finish Assy 05007 La Ves	ft	.500
UHMW 16	1" UHMW Plastic (SQ FT)	45007-636	Other Finish Assy 05007 La Ves	SQ F	.750
		45007-636	Other Finish Assy 05007 La Ves	SQ F	10.000
		45007-636	Other Finish Assy 05007 La Ves	SQ F	9.000
		45007-636	Other Finish Assy 05007 La Ves	SQ F	3.250

\*\*\* Report Options \*\*\*

Items: ALL

Assemblies: 45007-636 to 45007-636

\*\*\* End of Report \*\*\*

**Advanced Farm Equipment  
Produce Assemblies (Build)**

Date		Document	Type	Reference	Location	Quantity UOM	Unit Cost	Extended Cost
Item: 0000000.11				Fitting for Case Drain on Pocl				
07/13/05	Assembly		Build		1AFE	4.000- each	3.670	14.68-
Item: 20000-012				Char-Lynn Motor (104-1067)				
07/13/05	Assembly		Build		1AFE	7.000- each	261.600	1,831.20-
Item: 20000-021				3/4" High Pressure Hose				
07/13/05	Assembly		Build		1AFE	18.670- ft	4.950	92.42-
07/13/05	Assembly		Build		1AFE	8.080- ft	4.950	40.00-
Item: 20001-004				In-Tank Filter				
07/13/05	Assembly		Build		1AFE	3.000- each	44.510	133.53-
Item: 20001-015				16" Steering Cylinder				
07/13/05	Assembly		Build		1AFE	3.000- each	132.840	398.52-
Item: 20001-021				1" High Pressure Hose				
07/13/05	Assembly		Build		1AFE	43.500- ft	6.120	266.22-
07/13/05	Assembly		Build		1AFE	58.080- ft	6.120	355.45-
Item: 20002-004				In-Tank Filter Assembly				
07/13/05	Assembly		Build		1AFE	3.000- ea	177.330	531.99-
Item: 20002-015				2" x 6" Cylinder				
07/13/05	Assembly		Build		1AFE	1.000- each	69.830	69.83-
Item: 20003-004				High Pressure Filter				
07/13/05	Assembly		Build		1AFE	2.000- ea	621.750	1,243.50-
Item: 20003-010				Airhead Gear Box				
07/13/05	Assembly		Build		1AFE	1.000- each	1,174.630	1,174.63-
Item: 20003-014				Hyd Oil Cool				
07/13/05	Assembly		Build		1AFE	1.000- each	1,553.660	1,553.66-
Item: 20003-015				2" x 10" Cylinder				
07/13/05	Assembly		Build		1AFE	3.000- each	79.520	238.56-
Item: 20004-004				Inline Filter				
07/13/05	Assembly		Build		1AFE	1.000- ea	93.791	93.79-
Item: 20004-011				90 Deg. Tube Adapter 16x16				
07/13/05	Assembly		Build		1AFE	10.000- each	28.778	287.78-
Item: 20004-013				3 Bank Pulsar Valve				
07/13/05	Assembly		Build		1AFE	1.000- each	1,401.560	1,401.56-
Item: 20005-004				Inline Filter Element				
07/13/05	Assembly		Build		1AFE	1.000- ea	12.410	12.41-
Item: 20007-010				Eskridge Gear Box - Series 28				
07/13/05	Assembly		Build		1AFE	5.000- each	763.524	3,817.62-
Item: 20007-012				Steering Motor (212-1017)				
07/13/05	Assembly		Build		1AFE	1.000- each	342.240	342.24-

**Advanced Farm Equipment  
Produce Assemblies (Build)**

Date		Document	Type	Reference	Location	Quantity UOM	Unit Cost	Extended Cost
Item: 20007-014	07/13/05	Assembly	Build	Pressure Gauge 0-600 PSI	1AFE	1.000- each	7.650	7.65-
Item: 20008-012	07/13/05	Assembly	Build	Steering Mtr-Column Adapter	1AFE	1.000- each	36.480	36.48-
Item: 20009-004	07/13/05	Assembly	Build	Spin on Filter Element	1AFE	3.000- ea	13.563	40.69-
Item: 20009-014	07/13/05	Assembly	Build	Pressure Gauge 0-5000 PSI	1AFE	1.000- each	7.650	7.65-
Item: 20009-020	07/13/05	Assembly	Build	Paraflex Element	1AFE	1.000- each	112.080	112.08-
Item: 20010-004	07/13/05	Assembly	Build	1 1/2" Single Filter Head	1AFE	1.000- ea	17.435	17.44-
Item: 20010-009	07/13/05	Assembly	Build	PVE21L Pump	1AFE	1.000- each	485.100	485.10-
Item: 20010-013	07/13/05	Assembly	Build	2 Bank Pulsar Valve	1AFE	1.000- each	1,044.260	1,044.26-
Item: 20010-014	07/13/05	Assembly	Build	Pressure Gauge 0-10000 PSI	1AFE	1.000- each	7.650	7.65-
Item: 20010-015	07/13/05	Assembly	Build	3" x 8" Cylinder	1AFE	1.000- each	78.020	78.02-
Item: 20010-020	07/13/05	Assembly	Build	PX120 Paraflex Flange	1AFE	2.000- each	177.240	354.48-
Item: 20012-004	07/13/05	Assembly	Build	Double Filter Head	1AFE	1.000- ea	49.980	49.98-
Item: 20012-011	07/13/05	Assembly	Build	Adapter 90 Deg.	1AFE	2.000- each	60.760	121.52-
Item: 20012-015	07/13/05	Assembly	Build	3" x 12" Cylinder	1AFE	1.000- each	89.180	89.18-
Item: 20013-004	07/13/05	Assembly	Build	Intank Strainer	1AFE	3.000- ea	28.147	84.44-
Item: 20013-013	07/13/05	Assembly	Build	2 1/2" Ball Valve	1AFE	1.000- each	65.000	65.00-
Item: 20013-015	07/13/05	Assembly	Build	3" X 14" Cylinder	1AFE	2.000- ea	106.610	213.22-
Item: 20014-004	07/13/05	Assembly	Build	Intank Strainer (TF2540-3)	1AFE	1.000- ea	33.870	33.87-
Item: 20014-015	07/13/05	Assembly	Build	3" x 16" Cylinder	1AFE	2.000- each	113.010	226.02-



Advanced Farm Equipment  
Produce Assemblies (Build)

Date		Document	Type	Reference	Location	Quantity UOM	Unit Cost	Extended Cost
Item: 20015-015				3" x 24" Cylinder				
07/13/05	Assembly		Build		1AFE	1.000- each	136.100	136.10-
Item: 20016-010				DP49 Torsion Plate - 14"				
07/13/05	Assembly		Build		1AFE	1.000- ea	1,650.000	1,650.00-
Item: 20018-012				17.9 Cu. In. "S" Series Motor				
07/13/05	Assembly		Build		1AFE	8.000- each	206.710	1,653.68-
Item: 20019-014				3 inch Flexwrap Magnet				
07/13/05	Assembly		Build		1AFE	6.000- each	8.600	51.60-
Item: 20020-004				Low Pressure Return Filter				
07/13/05	Assembly		Build		1AFE	2.000- ea	176.960	353.92-
Item: 20020-012				MS18 Reg w/o Case Flushing				
07/13/05	Assembly		Build		1AFE	2.000- each	3,210.300	6,420.60-
Item: 20020-014				4 In Flex Wrap Magnet				
07/13/05	Assembly		Build		1AFE	2.000- each	11.900	23.80-
Item: 20021-004				Low Pressure Return Filter				
07/13/05	Assembly		Build		1AFE	1.000- ea	161.850	161.85-
Item: 20021-015				Cylinder 4x30 W/1 1/2" Rod				
07/13/05	Assembly		Build		1AFE	1.000- each	212.170	212.17-
Item: 20022-009				64 Hydro w/elec control RH Ser				
07/13/05	Assembly		Build		1AFE	1.000- each	2,676.170	2,676.17-
Item: 20023-004				Vacuum Gauge for Filter Heads				
07/13/05	Assembly		Build		1AFE	2.000- each	5.640	11.28-
Item: 20023-014				249BN70 O'Ring For Eskridge GB				
07/13/05	Assembly		Build		1AFE	5.000- ea	.380	1.90-
Item: 20023-015				2"x8" Cylinder w/Extension				
07/13/05	Assembly		Build		1AFE	4.000- each	71.980	287.92-
Item: 20024-004				Filter Element for RLT9VZ10 Fi				
07/13/05	Assembly		Build		1AFE	4.000- each	32.500	130.00-
Item: 20027-011				3/4" Hose End				
07/13/05	Assembly		Build		1AFE	10.000- ea	11.450	114.50-
07/13/05	Assembly		Build		1AFE	4.000- ea	11.450	45.80-
Item: 20027-012				MS50 Long RH w/Br, 2Speed,S Se				
07/13/05	Assembly		Build		1AFE	1.000- each	7,525.840	7,525.84-
Item: 20028-009				Tandem 3.0 Electronic Pump				
07/13/05	Assembly		Build		1AFE	2.000- each	3,079.000	6,158.00-
Item: 20028-011				1" Hose End				
07/13/05	Assembly		Build		1AFE	38.000- ea	13.070	496.66-

Advanced Farm Equipment  
Produce Assemblies (Build)

Document						Unit	Extended
Date	Number	Type	Reference	Location	Quantity UOM	Cost	Cost
Item: 20028-012			MS50 Long LH w/Br, 2Speed,S Se				
07/13/05	Assembly	Build		1AFE	1.000- each	7,525.840	7,525.84-
Item: 20029-009			35VQT Vane Pump				
07/13/05	Assembly	Build		1AFE	1.000- each	1,081.500	1,081.50-
Item: 20031-013			Air Head Cleaner Valve				
07/13/05	Assembly	Build		1AFE	1.000- ea	90.680	90.68-
Item: 20033-009			V10 Pump RH Splined Shaft 7GPM				
07/13/05	Assembly	Build		1AFE	1.000- each	221.450	221.45-
Item: 20033-012			CharLynn 6000 Motor 11.9 Cu.In				
07/13/05	Assembly	Build		1AFE	5.000- each	529.920	2,649.60-
Item: 20037-012			Eaton Motor (104-1062)				
07/13/05	Assembly	Build		1AFE	1.000- ea	241.440	241.44-
Item: 20038-009			Tandem 64 Hydro Pump -Series 2				
07/13/05	Assembly	Build		1AFE	1.000- ea	5,301.510	5,301.51-
Item: 20039-011			Test Point Fitting				
07/13/05	Assembly	Build		1AFE	3.000- each	12.500	37.50-
Item: 20040-011			Test Point Fitting				
07/13/05	Assembly	Build		1AFE	3.000- each	7.280	21.84-
Item: 20042-011			1/2" JIC 90 Sweep				
07/13/05	Assembly	Build		1AFE	4.000- ea	5.810	23.24-
Item: 20042-012			Hydraulic Motor				
07/13/05	Assembly	Build		1AFE	1.000- ea	1,203.000	1,203.00-
Item: 20042-013			Cylinder Valve (Rear Steering)				
07/13/05	Assembly	Build		1AFE	1.000- each	247.610	247.61-
Item: 20043-012			Hydraulic Motor				
07/13/05	Assembly	Build		1AFE	1.000- ea	1,256.100	1,256.10-
Item: 20043-013			Single Valve Bank Section w/co				
07/13/05	Assembly	Build		1AFE	1.000- each	136.490	136.49-
Item: 20044-013			FPS Valve Section W/Check				
07/13/05	Assembly	Build		1AFE	7.000- ea	211.405	1,479.84-
Item: 20045-013			Bolt Kit for 3 Bank MV5				
07/13/05	Assembly	Build		1AFE	1.000- each	14.230	14.23-
Item: 20047-013			MV5 Valve Bank Outlet Side				
07/13/05	Assembly	Build		1AFE	5.000- each	20.840	104.20-
Item: 20048-013			MV5 Valve Bank Inlet Section				
07/13/05	Assembly	Build		1AFE	5.000- each	14.464	72.32-
Item: 20049-013			1/2" Needle Valve w/Check				
07/13/05	Assembly	Build		1AFE	2.000- each	17.540	35.08-

**Advanced Farm Equipment  
Produce Assemblies (Build)**

Date		Document		Location	Quantity UOM	Unit Cost	Extended Cost
Date	Number	Type	Reference	Location	Quantity UOM	Unit Cost	Extended Cost
07/13/05	Assembly	Build	AC Hose Kit (Inc All Hoses)	1AFE	1.000- ea	462.060	462.06-
07/13/05	Assembly	Build	3/8" Needle Valve	1AFE	9.000- each	21.169	190.52-
07/13/05	Assembly	Build	1/2" Needle Valve	1AFE	1.000- each	26.100	26.10-
07/13/05	Assembly	Build	Comm. Trip. CCW	1AFE	1.000- ea	936.730	936.73-
07/13/05	Assembly	Build	Charr-Lynn Motor	1AFE	1.000- each	240.120	240.12-
07/13/05	Assembly	Build	3/4" High Pressure Sweep	1AFE	4.000- each	8.886	35.54-
07/13/05	Assembly	Build	1.6 GPM Vonberg Flow Control	1AFE	2.000- each	16.000	32.00-
07/13/05	Assembly	Build	Reversing Valve	1AFE	3.000- each	488.220	1,464.66-
07/13/05	Assembly	Build	Rear Steering Relief Valve	1AFE	1.000- each	97.240	97.24-
07/13/05	Assembly	Build	MS-18 3/4" Split Flange	1AFE	4.000- each	8.973	35.89-
07/13/05	Assembly	Build	Four Bank Circuit Control Valv	1AFE	2.000- each	916.000	1,832.00-
07/13/05	Assembly	Build	1" Long High Pressure Sweep	1AFE	3.000- each	30.450	91.35-
07/13/05	Assembly	Build	White Flow Divider	1AFE	1.000- each	431.090	431.09-
07/13/05	Assembly	Build	Proportional Flow Divider	1AFE	1.000- each	122.060	122.06-
07/13/05	Assembly	Build	Breakaway Valve	1AFE	1.000- each	133.320	133.32-
07/13/05	Assembly	Build	Casappa Pump	1AFE	1.000- ea	450.250	450.25-
07/13/05	Assembly	Build	Gresen Check Valve	1AFE	1.000- ea	14.860	14.86-
07/13/05	Assembly	Build	High Pressure Relief Valve	1AFE	6.000- each	24.471	146.83-
07/13/05	Assembly	Build	Shut Off Valve				

**Advanced Farm Equipment  
Produce Assemblies (Build)**

Date		Document		Location	Quantity UOM	Unit Cost	Extended Cost
Date	Number	Type	Reference	Location	Quantity UOM	Unit Cost	Extended Cost
07/13/05	Assembly	Build		1AFE	1.000- each	95.480	95.48-
Item: 20067-013			N.C. Solenoid Valve				
07/13/05	Assembly	Build		1AFE	1.000- ea	47.080	47.08-
Item: 20071-013			2" Ball Valve				
07/13/05	Assembly	Build		1AFE	8.000- each	27.067	216.54-
Item: 20075-014			Gauge Snubber				
07/13/05	Assembly	Build		1AFE	3.000- each	5.508	16.52-
Item: 20076-014			Oil Tank Sight Gauge				
07/13/05	Assembly	Build		1AFE	1.000- each	32.715	32.72-
Item: 20083-013			30 Gal Flow Control w/relief				
07/13/05	Assembly	Build		1AFE	13.000- each	60.344	784.47-
Item: 20PH			1 1/4" Split Flange				
07/13/05	Assembly	Build		1AFE	4.000- ea	18.720	74.88-
Item: 21018-018			3020 3" Taperlock Bushing				
07/13/05	Assembly	Build		1AFE	1.000- each	17.440	17.44-
Item: 21019-018			3020-1 3/4 Taper Lock Bushing				
07/13/05	Assembly	Build		1AFE	1.000- each	17.980	17.98-
Item: 22022-023			3/4" Gas Ball Valve				
07/13/05	Assembly	Build		1AFE	5.000- each	6.990	34.95-
Item: 24SA 08			1/2" NPT Hydraulic Nipple				
07/13/05	Assembly	Build		1AFE	1.000- each	1.250	1.25-
Item: 24SA 12			3/4" NPT Hydraulic Nipple				
07/13/05	Assembly	Build		1AFE	3.000- each	.970	2.91-
Item: 24SA 12x08			3/4" x 1/2" NPT Hydrallc Nipp				
07/13/05	Assembly	Build		1AFE	3.000- each	2.150	6.45-
Item: 24SB 12x08			3/4" x 1/2" NPT Hydraulic Bush				
07/13/05	Assembly	Build		1AFE	2.000- each	1.360	2.72-
Item: 24SJ 08			1/2" NPT Hydraulic Coupler				
07/13/05	Assembly	Build		1AFE	1.000- each	2.200	2.20-
Item: 25184-018			5018 Chain Coupler Assembly				
07/13/05	Assembly	Build		1AFE	1.000- each	10.010	10.01-
Item: 25UG 08			1/2" NPT Hydraulic 90 ST. EL.				
07/13/05	Assembly	Build		1AFE	2.000- each	2.340	4.68-
Item: 25UG 12			3/4" NPT Hydraulic 90 ST. EL.				
07/13/05	Assembly	Build		1AFE	4.000- each	7.260	29.04-
Item: 25VK 08			1/2" NPT Hydraulic Service Tee				
07/13/05	Assembly	Build		1AFE	1.000- each	7.150	7.15-

**Advanced Farm Equipment  
Produce Assemblies (Build)**

Date		Document		Location	Quantity UOM	Unit Cost	Extended Cost
Date	Number	Type	Reference	Location	Quantity UOM	Unit Cost	Extended Cost
Item: 30003-004 07/13/05	Assembly	Build	Rivet Cutter	1AFE	1.000- ea	75.000	75.00-
Item: 30009-019 07/13/05	Assembly	Build	RDRS 112 Mounting Bracket	1AFE	1.000- each	4.841	4.84-
Item: 30020-019 07/13/05	Assembly	Build	Brake Release Bolts	1AFE	2.000- each	20.115	40.23-
Item: 30051-040 07/13/05	Assembly	Build	3/8"x 5" Fine Threaded Rod	1AFE	1.000- each	7.263	7.26-
07/13/05	Assembly	Build		1AFE	1.000 each	.270	.27
Item: 30060-019 07/13/05	Assembly	Build	Flow Divider Plate - Finished	1AFE	1.000- each	21.614	21.61-
Item: 3269 08-08 07/13/05	Assembly	Build	1/2" NPT x 1/2" Oring Adapter	1AFE	1.000- each	1.370	1.37-
Item: 341358 07/13/05	Assembly	Build	Univis N68 (Bulk)	1AFE	200.000- gal	6.114	1,222.80-
Item: 40000-004 07/13/05	Assembly	Build	Chain Tool Assembly	1AFE	2.000- each	34.715	69.43-
Item: 45007-616 07/13/05	Assembly	Build	Hydraulic Assy 05007 La Vesque	1AFE	1.000 ea	103,807.090	103,807.09
Item: 60SA 06x08 07/13/05	Assembly	Build	3/8" NPT male x 1/2" NPT Femal	1AFE	1.000- each	2.240	2.24-
Item: 60SA 08x12 07/13/05	Assembly	Build	1/2" NPT male x 3/4" NPT fema	1AFE	2.000- each	2.420	4.84-
Item: 63SE 12x16 07/13/05	Assembly	Build	3/4" Male JIC x 1" Flange	1AFE	2.000- each	16.340	32.68-
Item: 63SE 16x16 07/13/05	Assembly	Build	1" Male JIC x 1" Flange	1AFE	1.000- each	10.320	10.32-
Item: 63SF 12x12 07/13/05	Assembly	Build	3/4" Male JIC x 3/4" Flange	1AFE	4.000- each	8.560	34.24-
Item: 63SF 16x16 07/13/05	Assembly	Build	1" male JIC x 1" Flange	1AFE	2.000- each	17.000	34.00-
Item: 63TA 06x06 07/13/05	Assembly	Build	3/8" JIC 45 Sweep	1AFE	3.000- each	6.260	18.78-
Item: 63TA 08x08 07/13/05	Assembly	Build	1/2" JIC 45 Sweep	1AFE	12.000- each	6.374	76.49-
Item: 63TA 12x12 07/13/05	Assembly	Build	3/4" JIC 45 Sweep	1AFE	4.000- each	8.753	35.01-
Item: 63TF 16x16			63TF 16x16				

**Advanced Farm Equipment  
Produce Assemblies (Build)**

Date		Document		Location	Quantity	UOM	Unit Cost	Extended Cost
07/13/05	Assembly	Build		1AFE	6.000-	each	28.580	171.48-
Item: 63UA 06x06		3/8" JIC 90 Sweep						
07/13/05	Assembly	Build		1AFE	12.000-	each	4.350	52.20-
Item: 63UA 08x08		1/2" JIC 90 Sweep						
07/13/05	Assembly	Build		1AFE	51.000-	each	4.778	243.66-
Item: 63UA 10x10		90 Degree JIC Elbow						
07/13/05	Assembly	Build		1AFE	5.000-	ea	6.540	32.70-
Item: 63UA 12x12		3/4" JIC 90 Sweep						
07/13/05	Assembly	Build		1AFE	83.000-	each	7.920	657.36-
Item: 63UA 16x16		1" JIC 90 Sweep						
07/13/05	Assembly	Build		1AFE	4.000-	each	10.155	40.62-
Item: 63UC 12x12		3/4" JIC 90 Sweep						
07/13/05	Assembly	Build		1AFE	12.000-	each	9.038	108.46-
Item: 63UC 16x16		1" JIC Long 90 Sweep						
07/13/05	Assembly	Build		1AFE	1.000-	each	23.450	23.45-
Item: 63UE 16x16		1" male JIC x 1" Flange 90						
07/13/05	Assembly	Build		1AFE	1.000-	each	21.520	21.52-
Item: 63UF 16x16		1" Male JIC x 1" Flange						
07/13/05	Assembly	Build		1AFE	3.000-	each	32.640	97.92-
Item: 63UF 16x20		1" Male JIC x 1 1/4" Flange						
07/13/05	Assembly	Build		1AFE	4.000-	ea	36.040	144.16-
Item: 6402 06-08		3/8" Oring x 1/2" JIC Female						
07/13/05	Assembly	Build		1AFE	1.000-	each	2.930	2.93-
Item: 6402 12-12		3/4" Oring x 3/4" JIC female						
07/13/05	Assembly	Build		1AFE	9.000-	each	2.600	23.40-
Item: 6402 16-16		1" Oring x 1" JIC female						
07/13/05	Assembly	Build		1AFE	2.000-	each	6.330	12.66-
Item: 6403 NWO 12-12		3/4" Oring x 3/4" Oring						
07/13/05	Assembly	Build		1AFE	4.000-	each	3.430	13.72-
Item: 6410 06x04		6410 06x04						
07/13/05	Assembly	Build		1AFE	2.000-	each	.800	1.60-
Item: 6505 06-06		3/8" NPT x 3/8" JIC female						
07/13/05	Assembly	Build		1AFE	1.000-	each	1.120	1.12-
Item: 6505 08-06		3/8" NPT x 1/2" JIC female						
07/13/05	Assembly	Build		1AFE	11.000-	each	1.490	16.39-
Item: 721FSO 04		1/4" O'ring Plug Allen Head						
07/13/05	Assembly	Build		1AFE	5.000-	each	.730	3.65-
07/13/05	Assembly	Build		1AFE	2.000-	each	.730	1.46-

**Advanced Farm Equipment  
Produce Assemblies (Build)**

----- Document -----						Unit	Extended
Date	Number	Type	Reference	Location	Quantity UOM	Cost	Cost
Item: 721FSO 06		3/8" Oring Plug Hex Head					
07/13/05	Assembly	Build		1AFE	2.000- each	.730	1.46-
Item: 721FSO 08		1/2" Oring Plug					
07/13/05	Assembly	Build		1AFE	6.000- each	.410	2.46-
07/13/05	Assembly	Build		1AFE	2.000- each	.410	.82-
Item: 721FSO 10		5/8" Oring Plug					
07/13/05	Assembly	Build		1AFE	2.000- each	1.040	2.08-
07/13/05	Assembly	Build		1AFE	2.000- each	1.040	2.08-
Item: 721FSO 12		3/4" Oring Plug					
07/13/05	Assembly	Build		1AFE	2.000- each	.890	1.78-
07/13/05	Assembly	Build		1AFE	4.000- each	.890	3.56-
07/13/05	Assembly	Build		1AFE	13.000- each	.890	11.57-
Item: 721FSO 16		1" Oring Plug					
07/13/05	Assembly	Build		1AFE	2.000- each	2.170	4.34-
Item: 74R2566		Air Conditioner Drier					
07/13/05	Assembly	Build		1AFE	1.000- each	37.070	37.07-
Item: 830FS 04		1/4" JIC Cap					
07/13/05	Assembly	Build		1AFE	2.000- ea	.870	1.74-
Item: 830FS 06		3/8" JIC Cap					
07/13/05	Assembly	Build		1AFE	2.000- each	.230	.46-
Item: 830FS 08		1/2" JIC Cap					
07/13/05	Assembly	Build		1AFE	2.000- each	.370	.74-
Item: 830FS 10		5/8" JIC Cap					
07/13/05	Assembly	Build		1AFE	2.000- each	1.660	3.32-
Item: 830FS 12		3/4" JIC Cap					
07/13/05	Assembly	Build		1AFE	2.000- each	.720	1.44-
Item: 830FS 16		1" JIC Cap					
07/13/05	Assembly	Build		1AFE	2.000- each	1.050	2.10-
Item: 839FS 04		1/4" Plug JIC					
07/13/05	Assembly	Build		1AFE	2.000- ea	.710	1.42-
Item: 839FS 06		3/8" JIC Plug					
07/13/05	Assembly	Build		1AFE	2.000- each	.250	.50-
Item: 839FS 08		1/2" JIC Plug					
07/13/05	Assembly	Build		1AFE	2.000- each	.370	.74-
Item: 839FS 10		5/8" JIC Plug					
07/13/05	Assembly	Build		1AFE	2.000- each	1.570	3.14-
Item: 839FS 12		3/4" JIC Plug					
07/13/05	Assembly	Build		1AFE	2.000- each	.750	1.50-
07/13/05	Assembly	Build		1AFE	3.000- each	.750	2.25-

**Advanced Farm Equipment  
Produce Assemblies (Build)**

Date		Document		Location	Quantity UOM	Unit Cost	Extended Cost
Date	Number	Type	Reference	Location	Quantity UOM	Unit Cost	Extended Cost
Item: 839FS 16 07/13/05	Assembly	Build	1" JIC Plug	1AFE	2.000- each	1.240	2.48-
Item: 844FS 06 07/13/05	Assembly	Build	3/8" JIC 3way Male Tee	1AFE	2.000- each	3.050	6.10-
Item: 844FS 08 07/13/05	Assembly	Build	1/2" JIC 3way Male Tee	1AFE	2.000- each	3.430	6.86-
Item: 845FSO 06 07/13/05	Assembly	Build	3/8" JIC x 3/8" Oring Tee	1AFE	6.000- each	2.600	15.60-
Item: 845FSO 08 07/13/05	Assembly	Build	1/2" JIC x 1/2" Oring Tee	1AFE	2.000- each	5.720	11.44-
Item: 848FS 06x02 07/13/05	Assembly	Build	3/8" JIC x 1/8" NPT	1AFE	1.000- each	.505	.51-
Item: 848FS 06x04 07/13/05	Assembly	Build	3/8" JIC x 1/4" NPT	1AFE	1.000- each	.290	.29-
Item: 848FS 06x06 07/13/05	Assembly	Build	3/8" JIC x 3/8" NPT	1AFE	8.000- each	.573	4.58-
07/13/05	Assembly	Build		1AFE	5.000- each	.410	2.05-
Item: 848FS 06x08 07/13/05	Assembly	Build	3/8" JIC x 1/2" NPT	1AFE	4.000- each	.970	3.88-
Item: 848FS 08x06 07/13/05	Assembly	Build	1/2" JIC x 3/8" NPT	1AFE	7.000- each	.480	3.36-
Item: 848FS 08x08 07/13/05	Assembly	Build	1/2" JIC x 1/2" NPT	1AFE	7.000- each	.560	3.92-
Item: 848FS 08x12 07/13/05	Assembly	Build	1/2" JIC x 3/4" NPT	1AFE	5.000- each	1.070	5.35-
Item: 848FS 12x08 07/13/05	Assembly	Build	3/4" JIC x 1/2" NPT	1AFE	2.000- each	1.910	3.82-
Item: 848FS 12x12 07/13/05	Assembly	Build	3/4" JIC x 3/4" NPT	1AFE	13.000- each	1.289	16.76-
Item: 848FSO 06x04 07/13/05	Assembly	Build	3/8" JIC x 1/4" Oring	1AFE	13.000- each	.438	5.69-
Item: 848FSO 06x08 07/13/05	Assembly	Build	3/8" JIC x 1/2" Oring	1AFE	9.000- each	.807	7.27-
Item: 848FSO 08x06 07/13/05	Assembly	Build	1/2" JIC x 3/8" Oring	1AFE	21.000- each	.642	13.48-
Item: 848FSO 08x08 07/13/05	Assembly	Build	1/2" JIC x 1/2" Oring	1AFE	36.000- each	.835	30.06-



Advanced Farm Equipment  
Produce Assemblies (Build)

Date		Document		Location	Quantity UOM	Unit Cost	Extended Cost
Date	Number	Type	Reference	Location	Quantity UOM	Unit Cost	Extended Cost
07/13/05	Item: 848FSO 08x10 Assembly	Build	1/2" JIC x 5/8" Oring	1AFE	25.000- each	.998	24.96-
07/13/05	Item: 848FSO 08x12 Assembly	Build	1/2" JIC x 3/4" Oring	1AFE	35.000- each	2.250	78.74-
07/13/05	Item: 848FSO 12x08 Assembly	Build	3/4" JIC x 1/2" Oring	1AFE	2.000- each	1.817	3.63-
07/13/05	Item: 848FSO 12x10 Assembly	Build	3/4" JIC x 5/8" Oring	1AFE	20.000- each	1.200	24.00-
07/13/05	Item: 848FSO 12x12 Assembly	Build	3/4" JIC x 3/4" Oring	1AFE	82.000- each	1.230	100.86-
07/13/05	Item: 848FSO 12x16 Assembly	Build	3/4" JIC x 1" Oring	1AFE	25.000- each	3.489	87.23-
07/13/05	Item: 848FSO 12x20 Assembly	Build	3/4" JIC x 1 1/4" Oring	1AFE	4.000- each	9.640	38.56-
07/13/05	Item: 848FSO 16x12 Assembly	Build	1" JIC x 3/4" Oring	1AFE	1.000- each	3.010	3.01-
07/13/05	Item: 848FSO 16x16 Assembly	Build	1" JIC x 1" Oring	1AFE	14.000- each	2.090	29.26-
07/13/05	Item: 848FSO 16x20 Assembly	Build	1" JIC x 1 1/4" Oring	1AFE	4.000- each	3.430	13.72-
07/13/05	Item: 848LFSO 12 Assembly	Build	3/4" JIC x 3/4" Oring Long	1AFE	8.000- each	5.195	41.56-
07/13/05	Item: 849FS 06x02 Assembly	Build	3/8" JIC x 1/8" NPT 90	1AFE	2.000- each	2.063	4.13-
07/13/05	Item: 849FS 06x04 Assembly	Build	3/8" JIC x 1/4" NPT 90	1AFE	2.000- each	1.950	3.90-
07/13/05	Item: 849FS 06x06 Assembly	Build	3/8" JIC x 3/8" NPT 90	1AFE	3.000- each	1.480	4.44-
07/13/05	Item: 849FS 06x08 Assembly	Build	3/8" JIC x 1/2" NPT 90	1AFE	1.000- each	1.860	1.86-
07/13/05	Item: 849FS 08x08 Assembly	Build	1/2" JIC x 1/2" NPT 90	1AFE	4.000- each	2.050	8.20-
07/13/05	Item: 849FSO 06x04 Assembly	Build	3/8" JIC x 1/4" Oring 90	1AFE	2.000- each	5.820	11.64-
07/13/05	Item: 849FSO 06x06 Assembly	Build	3/8" JIC x 3/8" Oring 90	1AFE	14.000- each	2.630	36.82-
07/13/05	Item: 849FSO 06x08 Assembly	Build	3/8" JIC x 1/2" Oring 90	1AFE	2.000- each	1.720	3.44-

**Advanced Farm Equipment  
Produce Assemblies (Build)**

Date		Document	Type	Reference	Location	Quantity UOM	Unit Cost	Extended Cost
07/13/05	Assembly	Item: 849FSO 08x06	Build	1/2" JIC x 3/8" Oring	1AFE	2.000- each	4.860	9.72-
07/13/05	Assembly	Item: 849FSO 06x08	Build	1/2" JIC x 1/2" Oring	1AFE	11.000- each	1.400	15.40-
07/13/05	Assembly	Item: 849FSO 12x12	Build	3/4" JIC x 3/4" Oring 90	1AFE	3.000- each	5.040	15.12-
07/13/05	Assembly	Item: 851FSO 08	Build	1/2" JIC x 1/2" Oring Tee	1AFE	2.000- each	6.060	12.12-
07/13/05	Assembly	Item: 851FSO 12	Build	3/4" JIC x 3/4" Oring Tee	1AFE	15.000- each	7.836	117.54-
07/13/05	Assembly	Item: 854FSO 08x08	Build	1/2" JIC x 1/2" Oring 45	1AFE	1.000- each	3.730	3.73-
07/13/05	Assembly	Item: 854FSO 12x12	Build	3/4" JIC x 3/4" Oring 45	1AFE	13.000- each	4.590	59.67-
07/13/05	Assembly	Item: 871FS 06	Build	3/8" JIC x 3/8" JIC Swivel Tee	1AFE	4.000- each	1.570	6.28-
07/13/05	Assembly	Item: 871FS 08	Build	1/2" JIC x 1/2" JIC Swivel Tee	1AFE	8.000- each	2.200	17.60-
07/13/05	Assembly	Item: 871FS 12	Build	3/4" JIC x 3/4" JIC Swivel Tee	1AFE	13.000- each	4.200	54.60-
07/13/05	Assembly	Item: 871FS 12x04	Build	In Line Testing Tee	1AFE	3.000- each	9.497	28.49-
07/13/05	Assembly		Build		1AFE	4.000- each	9.497	37.99-
07/13/05	Assembly	Item: 871FS 16	Build	1" JIC x 1" JIC Swivel Tee	1AFE	2.000- each	5.470	10.94-
07/13/05	Assembly	Item: 872FS 06	Build	3/8" JIC x 3/8" JIC Swivel Te	1AFE	2.000- each	1.650	3.30-
07/13/05	Assembly	Item: 872FS 08	Build	1/2" JIC x 1/2" JIC Swivel Tee	1AFE	1.000- each	6.180	6.18-
07/13/05	Assembly	Item: 872FS 12	Build	3/4" JIC x 3/4" JIC Swivel Tee	1AFE	3.000- each	10.407	31.22-
07/13/05	Assembly	Item: 881-16	Build	1" Suction Hose	1AFE	9.000- ft	2.850	25.65-
07/13/05	Assembly	Item: 881-20	Build	1 1/4" Suction Hose	1AFE	9.333- ft	3.310	30.89-
07/13/05	Assembly	Item: 881-24	Build	1 1/2" Suction Hose	1AFE	12.333- ft	4.413	54.42-

**Advanced Farm Equipment  
Produce Assemblies (Build)**

Date		Document	Type	Reference	Location	Quantity	UOM	Unit Cost	Extended Cost
Item: 881-32				2" Suction Hose (GY=C232)					
07/13/05	Assembly		Build		1AFE	40.667-	ft	4.390	178.53-
Item: 881-40				2 1/2" Suction Hose					
07/13/05	Assembly		Build		1AFE	4.000-	ft	11.300	45.20-
Item: 881FS 08x08				1/2" NPT x 1/2" Female JIC					
07/13/05	Assembly		Build		1AFE	4.000-	each	1.360	5.44-
Item: 883FS 10x08				5/8" x 1/2" JIC Reducer					
07/13/05	Assembly		Build		1AFE	20.000-	each	.930	18.60-
Item: 883FS 12x08				3/4" x 1/2" JIC Reducer					
07/13/05	Assembly		Build		1AFE	10.000-	each	1.470	14.70-
Item: 883FS 16x12				1" x 3/4" JIC Reducer					
07/13/05	Assembly		Build		1AFE	4.000-	each	4.914	19.65-
Item: 93100				1" Hose Wrap - Black					
07/13/05	Assembly		Build		1AFE	30.000-	ft	1.054	31.62-
Item: 93150				1 1/2" Hose Wrap - Black					
07/13/05	Assembly		Build		1AFE	20.000-	ft	1.636	32.72-
Item: 93200				2" Hose Wrap - Black					
07/13/05	Assembly		Build		1AFE	40.000-	ft	2.321	92.84-
Item: B27084AZKT				Clevis & Pin Kit (Airhead Leve					
07/13/05	Assembly		Build		1AFE	1.000-	each	2.240	2.24-
Item: BK1132				2" Cap Black Pipe					
07/13/05	Assembly		Build		1AFE	1.000-	ea	3.716	3.72-
Item: BK124				1 1/2" CLS Nipple Black Pipe					
07/13/05	Assembly		Build		1AFE	5.000-	each	1.900	9.50-
Item: BK132				2" CLS Nipple Black Pipe					
07/13/05	Assembly		Build		1AFE	11.000-	each	2.746	30.20-
Item: BK140				2 1/2" CLS Nipple Black Pipe					
07/13/05	Assembly		Build		1AFE	1.000-	each	7.830	7.83-
Item: BK31632				1" x 2" Bushing Black Pipe					
07/13/05	Assembly		Build		1AFE	1.000-	each	2.930	2.93-
Item: BK32032				1 1/4" x 2" Bushing					
07/13/05	Assembly		Build		1AFE	4.000-	each	3.260	13.04-
Item: BK32432				1 1/2" x 2" Bushing Black Pipe					
07/13/05	Assembly		Build		1AFE	6.000-	each	2.961	17.77-
Item: BK33248				2" x 3" Bushing Black Pipe					
07/13/05	Assembly		Build		1AFE	1.000-	each	3.132	3.13-
Item: BK33264				2" X 4" Bushing Black Pipe					
07/13/05	Assembly		Build		1AFE	1.000-	each	12.540	12.54-

Date		Document		Location	Quantity UOM	Unit Cost	Extended Cost
Item: BK432		2" 90 ST EL Black Pipe					
07/13/05	Assembly	Build		1AFE	6.000- each	8.217	49.30-
Item: BK624		1 1/2" 45 ST EL					
07/13/05	Assembly	Build		1AFE	3.000- each	6.650	19.95-
Item: BK832		2" Tee Black Pipe					
07/13/05	Assembly	Build		1AFE	4.000- each	9.778	39.11-
Item: BTFW 1/4		1/4" Flat Washer					
07/13/05	Assembly	Build		1AFE	2.000- each	.016	.03-
Item: BTHH 1/2X1 1/2-G8		1/2"-13 x 1 1/2" HHCS GRADE 8					
07/13/05	Assembly	Build		1AFE	16.000- each	.117	1.87-
07/13/05	Assembly	Build		1AFE	4.000- each	.117	.47-
Item: BTHH 1/4x1 3/4		1/4" x 1 3/4" HHCS					
07/13/05	Assembly	Build		1AFE	2.000- each	.048	.10-
Item: BTHH 1/4x2 1/4		1/4"-20 x 2 1/4" HHCS					
07/13/05	Assembly	Build		1AFE	4.000- each	.060	.24-
Item: BTHH 10Mx35		M10 x 1.5 x 35mm HHCS class 10					
07/13/05	Assembly	Build		1AFE	16.000- each	.237	3.79-
Item: BTHH 12mx40		12mm x 40mm HHCS-Grade 8.8					
07/13/05	Assembly	Build		1AFE	8.000- each	.230	1.84-
Item: BTHH 5/16x3/4		5/16"-18 x 3/4" HHCS					
07/13/05	Assembly	Build		1AFE	8.000- each	.050	.40-
Item: BTHN 1/4		1/4"-20 Hex Nut Gr 5 ZP					
07/13/05	Assembly	Build		1AFE	2.000- each	.023	.05-
Item: BTLW 1/2		1/2" Lock Washer					
07/13/05	Assembly	Build		1AFE	4.000- each	.033	.13-
Item: BTLW 1/2HC		1/2" High Collar Lock Washer					
07/13/05	Assembly	Build		1AFE	8.000- each	.068	.54-
Item: BTLW 1/4		1/4" Lock Washer					
07/13/05	Assembly	Build		1AFE	4.000- each	.009	.04-
07/13/05	Assembly	Build		1AFE	4.000- each	.009	.04-
Item: BTLW 10MHC		10mm High Collar Lock Washer					
07/13/05	Assembly	Build		1AFE	16.000- each	.027	.43-
Item: BTLW 12MHC		Metric 12 High Collar Lock Was					
07/13/05	Assembly	Build		1AFE	8.000- each	.026	.21-
Item: BTLW 3/8		3/8" Lock Washer					
07/13/05	Assembly	Build		1AFE	4.000- each	.017	.07-
Item: BTLW 5/16		5/16" Lock Washer					
07/13/05	Assembly	Build		1AFE	8.000- each	.011	.09-

**Advanced Farm Equipment  
Produce Assemblies (Build)**

Date		Number	Type	Reference	Location	Quantity UOM	Unit Cost	Extended Cost
Item: BTLW 7/16				7/16" Lock Washer				
07/13/05	Assembly		Build		1AFE	16.000- ea	.024	.38-
Item: BTSH 1/4x1				1/4"x1" SHCS				
07/13/05	Assembly		Build		1AFE	2.000- ea	.040	.08-
Item: BTSH 10-24x 1 1/4				10-24 x 1 1/4" SHCS				
07/13/05	Assembly		Build		1AFE	4.000- each	.038	.15-
Item: BTSH 3/8x3 1/2				3/8"-16 x 3 1/2" SHCS				
07/13/05	Assembly		Build		1AFE	4.000- each	.264	1.06-
Item: BTSH 7/16x4				7/16-14 x 4" SHCS				
07/13/05	Assembly		Build		1AFE	16.000- ea	.696	11.14-
Item: BTTR 3/8F				3/8"-24 NC Rod - Low Carbon				
07/13/05	Assembly		Build		1AFE	.420- ft	.619	.26-
Item: BW04x06FJ				1/4" Hose x 3/8" JIC Hose End				
07/13/05	Assembly		Build		1AFE	2.000- each	1.750	3.50-
07/13/05	Assembly		Build		1AFE	8.000- each	1.750	14.00-
Item: BW06x06FJ				3/8" Hose x 3/8" JIC Hose End				
07/13/05	Assembly		Build		1AFE	29.000- each	1.820	52.78-
07/13/05	Assembly		Build		1AFE	37.000- each	1.820	67.34-
Item: BW06x06FJ90T				3/8" Hose x 3/8" JIC 90 Hose E				
07/13/05	Assembly		Build		1AFE	1.000- each	3.230	3.23-
Item: BW06x08FJ				3/8" Hose x 1/2" JIC Hose End				
07/13/05	Assembly		Build		1AFE	5.000- each	1.960	9.80-
07/13/05	Assembly		Build		1AFE	6.000- each	1.960	11.76-
Item: BW08x08FJ				1/2" Hose x 1/2" JIC Hose End				
07/13/05	Assembly		Build		1AFE	88.000- each	2.100	184.80-
07/13/05	Assembly		Build		1AFE	57.000- each	2.100	119.70-
Item: BW08x08FJ90T				1/2" Hose x 1/2" JIC 90 Hose E				
07/13/05	Assembly		Build		1AFE	19.000- each	5.340	101.46-
07/13/05	Assembly		Build		1AFE	41.000- each	5.340	218.94-
Item: BW08x10FJ				1/2" Hose x 5/8" JIC Hose End				
07/13/05	Assembly		Build		1AFE	3.000- each	3.284	9.85-
Item: BW12x12FJ				3/4" Hose x 3/4" JIC Hose End				
07/13/05	Assembly		Build		1AFE	153.000- each	4.143	633.87-
07/13/05	Assembly		Build		1AFE	94.000- each	4.090	384.46-
Item: BW16x16FJ				1" Hose x 1" JIC Hose End				
07/13/05	Assembly		Build		1AFE	11.000- each	7.610	83.71-
Item: BXP04				1/4" Hydraulic Hose				
07/13/05	Assembly		Build		1AFE	22.750- ft	.950	21.61-
Item: BXP06				3/8" Hydraulic Hose				

**Advanced Farm Equipment  
Produce Assemblies (Build)**

Date		Document	Type	Reference	Location	Quantity UOM	Unit Cost	Extended Cost
07/13/05	Assembly		Build		1AFE	50.917- ft	1.090	55.50-
07/13/05	Assembly		Build		1AFE	62.333- ft	1.090	67.94-
07/13/05	Assembly		Build		1AFE	43.167- ft	1.090	47.05-
Item: BXP08			1/2" Hydraulic Hose					
07/13/05	Assembly		Build		1AFE	115.333- ft	1.390	160.31-
07/13/05	Assembly		Build		1AFE	238.833- ft	1.390	331.98-
07/13/05	Assembly		Build		1AFE	112.917- ft	1.390	156.96-
Item: BXP12			3/4" Hydraulic Hose					
07/13/05	Assembly		Build		1AFE	185.333- ft	2.090	387.35-
07/13/05	Assembly		Build		1AFE	215.830- ft	2.090	451.09-
07/13/05	Assembly		Build		1AFE	192.167- ft	2.090	401.63-
Item: BXP16			1" Hydraulic Hose					
07/13/05	Assembly		Build		1AFE	28.750- ft	3.492	100.39-
Item: CDC-0126-1			Aluminum Manifold					
07/13/05	Assembly		Build		1AFE	2.000- each	79.000	158.00-
Item: CDC-0127-1			Aluminum Manifold					
07/13/05	Assembly		Build		1AFE	1.000- each	132.000	132.00-
Item: CR4475812			Brake/2speed Fitting for MS35/					
07/13/05	Assembly		Build		1AFE	4.000- each	11.480	45.92-
Item: DTS-0150D			Ground Drive Manifold					
07/13/05	Assembly		Build		1AFE	1.000- each	2,216.000	2,216.00-
Item: DTS-0155A			Brake Charge Pressure Valve					
07/13/05	Assembly		Build		1AFE	1.000- each	239.730	239.73-
Item: DTS-2349			1" Split Flange (Use w/ "F")					
07/13/05	Assembly		Build		1AFE	11.000- each	14.490	159.39-
Item: DTS-2455			1" Split Flange (Use with "E")					
07/13/05	Assembly		Build		1AFE	4.000- each	6.500	26.00-
Item: DTS-4276			Ground Drive Flow Divider Bloc					
07/13/05	Assembly		Build		1AFE	1.000- ea	852.000	852.00-
Item: DTS-6505-1			Solenoid Manifold					
07/13/05	Assembly		Build		1AFE	1.000- ea	30.800	30.80-
Item: DTS-7005-1			Rtrn Filtr Manfld U/W 20021-004					
07/13/05	Assembly		Build		1AFE	4.000- ea	101.000	404.00-
Item: FDC1-10-10T-66			Flow Divider w/5/8" Inlet					
07/13/05	Assembly		Build		1AFE	1.000- each	59.800	59.80-
Item: FT-100			1" Hose Barb					
07/13/05	Assembly		Build		1AFE	2.000- each	1.615	3.23-
Item: FT-125			1 1/4" Hose Barb					
07/13/05	Assembly		Build		1AFE	4.000- each	2.080	8.32-

**Advanced Farm Equipment  
Produce Assemblies (Build)**

Date		Document	Type	Reference	Location	Quantity UOM	Unit Cost	Extended Cost
Item: FT-150				1 1/2" Hose Barb				
07/13/05	Assembly		Build		1AFE	4.000- each	2.436	9.74-
Item: FT-200				2" Hose Barb				
07/13/05	Assembly		Build		1AFE	2.000- each	3.925	7.85-
Item: FT-250				2 1/2" Hose Barb				
07/13/05	Assembly		Build		1AFE	1.000- each	6.575	6.58-
Item: HC100				1" Hose Clamp				
07/13/05	Assembly		Build		1AFE	2.000- each	2.420	4.84-
Item: HC125				1 1/4" Hose Clamp				
07/13/05	Assembly		Build		1AFE	4.000- each	2.459	9.84-
Item: HC150				1 1/2" Hose Clamp				
07/13/05	Assembly		Build		1AFE	12.000- each	2.459	29.51-
Item: HC200				2" Hose Clamp				
07/13/05	Assembly		Build		1AFE	20.000- each	2.690	53.80-
Item: HL16x16FJ				1" High Pressure Hose End				
07/13/05	Assembly		Build		1AFE	2.000- each	7.610	15.22-
Item: HTB16				1" High Pressure Hose				
07/13/05	Assembly		Build		1AFE	4.830- each	5.500	26.57-
Item: HY10x08FJ				HOSE END				
07/13/05	Assembly		Build		1AFE	9.000- each	2.930	26.37-
Item: HY10x10FJ				Fuel Line Hose End				
07/13/05	Assembly		Build		1AFE	1.000- each	6.216	6.22-
Item: LEN-AFE				AFE Labor 1/4 Hour				
07/13/05	Assembly		Build		1AFE	.001- 1/4h	13.000	.01-
07/13/05	Assembly		Build		1AFE	1,129.000- 1/4h	12.500	14,112.50-
Item: MV5-1BK				Bolt Kit for 1 Bank MV5				
07/13/05	Assembly		Build		1AFE	3.000- each	11.800	35.40-
Item: MV5-2BK				Bolt Kit for 2 Bank MV5				
07/13/05	Assembly		Build		1AFE	1.000- each	12.860	12.86-
Item: OR-710FSO 04				710FSO-04 Oring				
07/13/05	Assembly		Build		1AFE	5.000- ea	.050	.25-
Item: OR-710FSO 06				710FSO-06 Oring				
07/13/05	Assembly		Build		1AFE	5.000- each	.070	.35-
Item: OR-710FSO 08				710FSO-08 Oring				
07/13/05	Assembly		Build		1AFE	5.000- each	.070	.35-
Item: OR-710FSO 10				710FSO-10 Oring				
07/13/05	Assembly		Build		1AFE	5.000- ea	.079	.40-
Item: OR-710FSO 12				710FSO-12 Oring				

07/13/05  
11:48AM

**Advanced Farm Equipment  
Produce Assemblies (Build)**

Date		Document		Location	Quantity UOM	Unit Cost	Extended Cost
07/13/05	Assembly	Build		1AFE	5.000- each	.060	.40-
Item: OR-710FSO 16		710FSO-16 Oring					
07/13/05	Assembly	Build		1AFE	5.000- each	.130	.65-
Item: OR-710FSO 20		710FSO-20 Oring					
07/13/05	Assembly	Build		1AFE	5.000- each	.186	.93-
Item: ORF-32-90		2" Suction w/ Flange					
07/13/05	Assembly	Build		1AFE	4.000- each	30.682	122.73-
Item: RDRS175-16		16 Gal Flow Control w/relief					
07/13/05	Assembly	Build		1AFE	3.000- each	55.602	166.81-
Item: RLT9VZ10S20MS10LC		Return Filter Elec. Indicator					
07/13/05	Assembly	Build		1AFE	1.000- ea	243.710	243.71-
Item: RV5-10-S-0-3/		300psi Relief Valve Cartridge					
07/13/05	Assembly	Build		1AFE	2.000- each	31.500	63.00-
Item: VS-01-1-3-1		Timer Valve Subplate					
07/13/05	Assembly	Build		1AFE	1.000- each	21.750	21.75-
Item: W43-32PK		2" NPT Flange Adapter					
07/13/05	Assembly	Build		1AFE	2.000- each	23.290	46.58-
Item: Y912		Fuel Line Hose					
07/13/05	Assembly	Build		1AFE	18.750- ft	3.350	62.81-
<b>Report Total:</b>							<u>.00</u>